

Portable Magnetic Drills



MABasic Series *p. 28-31*
Capacity: \varnothing 1-3/8" to 3-1/16" cutter
Professional grade, versatile



MAB 155 *p. 32*
Capacity: \varnothing 1-1/2" cutter
For drilling in tight spaces



AutoMAB 350 *p. 34*
Capacity: \varnothing 1-1/2" cutter
Automatic feed – forward and reverse



AutoMAB 450 *p. 35*
Capacity: \varnothing 2" cutter; \varnothing 3/4" twist drill
Automatic feed – forward and reverse



MAB 465 *p. 36*
Capacity: \varnothing 2" cutter; \varnothing 5/8" twist drill
Reversible, 2-gear motor



MAB 485 & MAB 485 SB *p. 38*
Capacity: \varnothing 2-1/16" cutter; \varnothing 7/8" twist drill;
 \varnothing 15/16" tapping
Reversible, 2-gear motor
Swivel base (MAB 485 SB)



MAB 525 & MAB 525 SB *p. 40*
Capacity: \varnothing 2-1/2" cutter; \varnothing 1" twist drill;
 \varnothing 15/16" tapping
Reversible, 2-gear motor
Swivel base (MAB 525 SB)



MAB 825 KTS *p. 42*
Capacity: \varnothing 3-1/8" cutter; \varnothing 1-1/4" twist drill;
 \varnothing 1-3/16" tapping
Multi-axis positioning for boring, slotting, etc.
Reversible, 4-gear motor



MAB 825, MAB 825 V & MAB 845 *p. 44*
Capacity: \varnothing 4-1/16" cutter; \varnothing 1-1/4" twist drill;
 \varnothing 1-1/8" tapping
Auto feed (MAB 825 V) Swivel base (MAB 845)
Reversible, 4-gear motor



MAB 1300 & MAB 1300 V *p. 46-49*
Capacity: \varnothing 5-1/8" cutter
 \varnothing 1-3/4" twist drill
 \varnothing 1-5/8" tapping
Reversible, 4-gear motor
Auto-feed and reverse (MAB 1300 V)
The ultimate in power



AIRBOR™ AB-4300 *p.50*
Pneumatic power
Capacity: \varnothing 2-1/16" cutter; \varnothing 1/2" twist drill
ATEX for hazardous environments



HB 4400 *p. 51*
Hydraulic power
Capacity: \varnothing 2-1/16" cutter;
 \varnothing 1/2" twist drill
For marine, construction
and underwater applications



Model 2 1345 0010 *p. 52*
Hydraulic power
Capacity: \varnothing 4" cutter; \varnothing 1-1/4" twist drill;
 \varnothing 1" tapping
ATEX certified

Warranty

Products of CS Unitec, Inc. are warranted to be free from defects in material and workmanship for one year from date of purchase. This warranty does not apply to normal wear or products which have been abused, misused, modified or repaired by someone other than CS Unitec, Inc. or its Authorized Service Representatives.

If a product proves defective in material or workmanship within one year after purchase, return it to CS Unitec, Inc. or an Authorized Service Center, transportation prepaid. CS Unitec, Inc. will, at its option, repair or replace defective products free of charge.

CS Unitec, Inc.'s sole liability and your exclusive remedy under this warranty is limited to repair or replacement of the defective product. There are no other warranties expressed or implied and CS Unitec, Inc. shall not be liable for incidental, consequential or special damages, or expenses excepting only the cost or expense of repair or replacement as described above.

Safety

Operators of any power tool should use appropriate safety precautions for work being performed. This includes safety chains, eye protection, hearing protection, gloves and more. Follow instructions included in operating manual.

Annular Cutters

p. 54-64

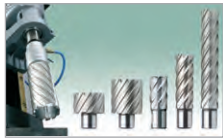

HSS Unibroach® p. 56-57

High-speed steel
7/16" to 5-1/8" diameter
1", 2" and 3" depth
Special sizes available



TiAlN Carbide-Coated Unibroach™ p. 58-59

For higher working temperatures
7/16" to 5-1/8" diameter
1", 2" and 3" depth



TCT Hornet p. 60-61

Tungsten carbide-tipped
1/2" to 5-1/8" diameter
1", 2-3/8" and 3-3/8" depth
Special sizes available

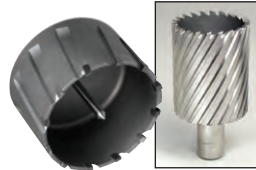

One-Touch TCT Cutters p. 62

Rail Cutters & Cobalt Cutters p. 63

Carbide-Tipped Hole Saws p. 64

Accessories

p. 65-71



Drilling Starter Kits p. 65

Lubricants and Pilot Pins p. 66

Arbors and Drill Chucks p. 67

Extensions and Tapping Tools p. 68

Countersinks, Drill/Taps and Chip Guard p. 68

MobilCLAMP p. 69

Convert magnetic drilling machine to bench drill

Drilling Stand and Vise p. 69

Convert hand drill to drill press

Vacuum Plates p. 70

For channeled plates and smooth surfaces

Metal Chip Cleanup Tools p. 70

Pipe Saddle Clamp System p. 71

Safe, secure drilling of pipes and tubular material



Custom Machines & Motors, Hand-Held Drills, Drive Units and More

p. 72-80



Electric, Slow-Speed Electric Drills & Drive Units p. 72-73

Electric Drive Units/Special Motors p. 74

Custom-Engineered Machines p. 75

Pneumatic Drills and Drive Units p. 76

Corner Drills and Drive Units p. 77

Pneumatic/Hydraulic Rotary Hammers p. 78

Pneumatic Woodboring Drills and AirPac p. 79

Pneumatic/Hydraulic Nut Runners p. 80



Portable Magnetic Drilling Machines

**Fast, accurate hole cutting...
on the job site or in the shop!**



Designed for continuous operation, CS Unitec's portable magnetic drills are ideal for drilling structural steel and virtually any metal. We offer the most compact, powerful and reliable series of portable magnetic drills for holes up to 5-1/8" diameter. All CS Unitec drills are heavy-duty for use in construction and industry. Our complete line includes electric, pneumatic and hydraulic tools. They are available for prompt delivery.

CS Unitec is the industry leader in:

- Power-to-weight ratios
- Strongest clamping force with high-density (HD) dual-coil magnets
- Magnetic drills for tapping
- Annular Cutters: TiAIN, HSS, cobalt steel and carbide-tipped

Our drills have unique features:

- Longest drill stroke in the industry
- Variable-speed, multiple-gear models
- Electric, pneumatic and hydraulic power
- Reversible motors for tapping
- Swivel base stand for hard-to-reach areas
- Battery-operated for on-site cordless drilling



Rugged construction and sophisticated functionality.

Intuitive magnets, ergonomic controls and simple operation for superior cuts.

Overheating Protection with CoolMag

COOLMAG™ Electromagnets

ensure that the magnet does not overheat. When the magnet is switched on for long periods of time, the coils could overheat or even burn out. The CoolMag feature reduces the power of the magnets when the drill motor is not active. Therefore, it won't build up heat.

CS Unitec high-density dual-coil magnets are ground, not cast, and are wound into two circles to increase the surface area and density of the magnetic field.



Keyless, quick-change system for annular cutters saves time and money. Just twist and lock.



Twist Drilling



Tapping



Reaming



Countersinking

Custom machines for unique applications

Our engineers can create a drill, drill rig, or other application-specific arrangement to meet your needs.

See page 75 for more information, or call 1-800-700-5919 for design assistance.

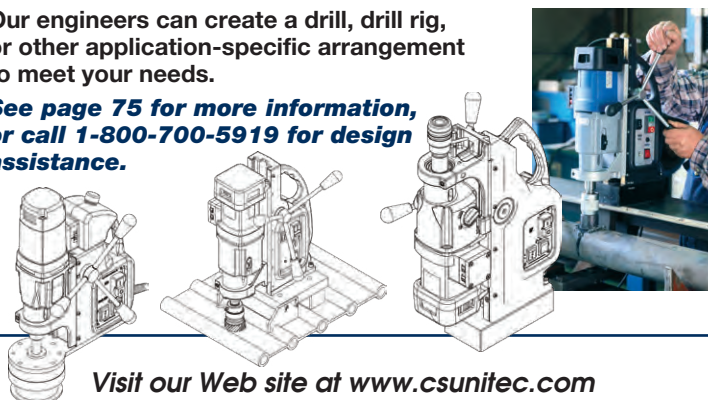
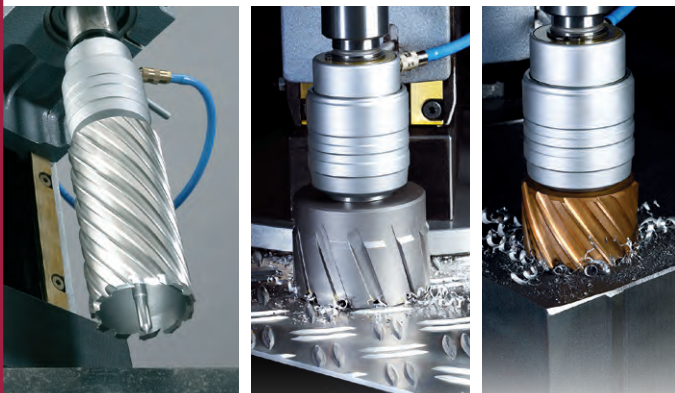

PORTABLE MAGNETIC DRILLS

The value is in the engineering...
the payback is in the performance.

IQ Magnetic System for Active Safety

Magnetic force is the key to safety and success.

The magnetic force of your magnet depends on a number of factors:

- ▶ Thickness of material being drilled
- ▶ Coatings or paint layers on material
- ▶ Chips, dirt or grease between the magnet and the material

SafeMag
System

**Electronic Safety
Shutoff Sensor**

The **SAFEMAG™ System** measures whether the magnet has sufficient adhesive force on the material. An LED indicator on the switch panel warns you of insufficient magnetic force (**Red Light**) or tells you if the correct force is present (**Green Light**).



LED red... insufficient magnetic force. Drilling should not take place. Possible causes are too-thin material, coatings of paint, scale or zinc.

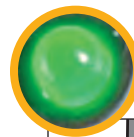
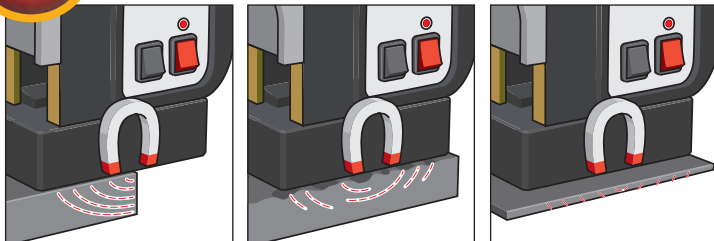

LED green... the magnetic adhesion meets the minimum requirements. Drilling can take place.

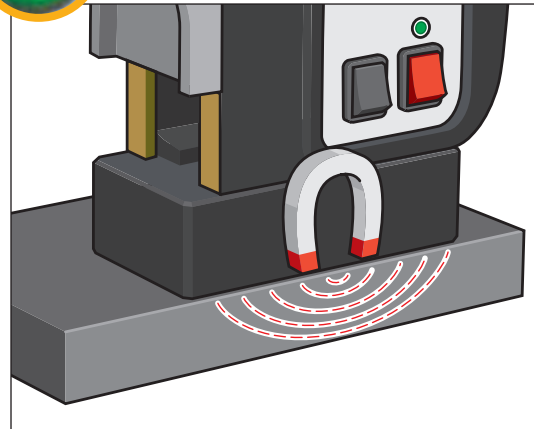

Our **Electronic Safety Shutoff Sensor** automatically shuts down the drill motor if the magnet loses contact with the material. This emergency-off feature helps to protect both operator and equipment.

Integrated cable routing: MAB Series

The new generation of our MAB portable magnetic drilling machines has been developed for increased safety. This includes complete cable routing within the casing.

- ▶ No threading and getting caught
- ▶ No tearing or snapping off

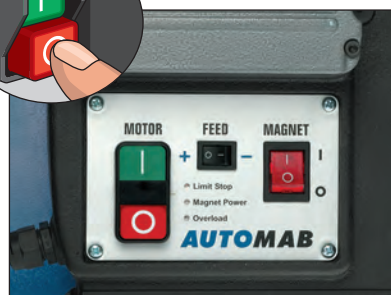
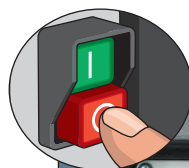

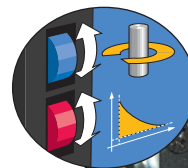

Simple, ergonomic arrangement of controls for one-handed operation. Emergency-off function for quick shutdown.



High power at low speeds. Electronic torque control prevents damage to motor.

Magnetic Drill Comparison Chart



	MABasic 200	MABasic 400	MABasic 450	MABasic 850	MAB 155	AutoMAB 350	AutoMAB 450	MAB 465
	Page 28	Page 29	Page 30	Page 31	Page 32	Page 34	Page 35	Page 36
Annular Cutters Diameter (ø)	up to ø 1-3/8"	up to ø 1-5/8"	up to ø 1-3/4"	up to ø 3-1/16"	up to ø 1-1/2"	up to ø 1-1/2"	up to ø 2"	up to ø 2"
Twist Drills Diameter (ø)	up to ø 1/2"	up to ø 5/8"	up to ø 3/4"	up to ø 1-1/4"		up to ø 1/2"	up to ø 3/4"	up to ø 5/8"
Tapping Diameter (ø)								up to ø 5/8"
Countersinking Diameter (ø)								up to ø 1-1/2"
Reaming Diameter (ø)								
Stroke	6-1/3"	6-1/3"	6-1/3"	10"	1-1/2"	6"	6"	6-1/3"
Weight	27 lbs.	27 lbs.	29 lbs.	53 lbs.	24 lbs.	33 lbs.	35-1/4 lbs.	29 lbs.
Speed Range 1	450 RPM	430 RPM	250 RPM	110 RPM	460 RPM	460 RPM	250 RPM	50-250 RPM
Speed Range 2		760 RPM	450 RPM	175 RPM			450 RPM	100-450 RPM
Speed Range 3				245 RPM				
Speed Range 4				385 RPM				
								✓
								✓
						✓	✓	✓
Electronic Safety Shutoff Sensor	✓	✓	✓		✓			✓
Tool Holder	Set Screw	Set Screw	Set Screw	Set Screw	Set Screw	Set Screw	Set Screw	Set Screw
Morse Taper (MT)			MT2				MT2	
Safety Friction Clutch								
Torque Control								
Swivel/Adjustable Base								
Magnet Size	6-5/8" x 3-1/3"	6-5/8" x 3-1/3"	6-5/8" x 3-1/3"	8-5/8" x 4-1/3"	6-5/16" x 3-3/16"	6-5/8" x 3-1/3"	6-5/8" x 3-1/3"	6-5/8" x 3-1/3"



MAB 485 MAB 485 SB	MAB 525 MAB 525 SB	MAB 825 KTS	MAB 825 MAB 825 V MAB 845	MAB 1300 MAB 1300 V	AIRBOR™	HB 4400	Model 2 1345 0010	Special Features
<i>Page 38</i>	<i>Page 40</i>	<i>Page 42</i>	<i>Page 44</i>	<i>Page 46</i>	<i>Page 50</i>	<i>Page 51</i>	<i>Page 52</i>	
up to ø 2-1/16"	up to ø 2-1/2"	up to ø 3-1/8"	up to ø 4-1/16"	up to ø 5-1/8"	up to ø 2-1/16"	up to ø 2-1/16"	up to ø 4"	Max. hole diameter up to 5-1/8"
up to ø 7/8"	up to ø 1"	up to ø 1-1/4"	up to ø 1-1/4"	up to ø 1-3/4"	up to ø 5/8"	up to ø 1/2"	up to ø 1-1/4"	Max. twist drilling up to 1-3/4"
up to ø 15/16"	up to ø 15/16"	up to ø 1-3/16"	up to ø 1-1/8"	up to ø 1-5/8"			up to ø 1"	Max. tapping up to 1-5/8"
up to ø 1-5/8"	up to ø 2"	up to ø 2"	up to ø 2"	up to ø 3"			up to ø 2"	
up to ø 7/8"	up to ø 7/8"	up to ø 1-1/4"	up to ø 1-1/4"	up to ø 2"			up to ø 1-1/8"	
6-1/3"	6-1/3"	10"	10"	3.35" (12" w/out retainer)	up to 10-1/4"	up to 3-3/4"	12"	
29 lbs.	35 lbs.	99 lbs.	55 lbs.	112 lbs.	43 lbs.	48-1/2 lbs.	50 lbs.	
50-250 RPM	70-280 RPM	40-110 RPM	40-110 RPM	30-80 RPM	400 RPM	0-630 RPM	40-250 RPM	Pneumatic Hydraulic
100-450 RPM	180-580 RPM	65-175 RPM	65-175 RPM	50-120 RPM				
		140-360 RPM	140-360 RPM	130-350 RPM				
		220-600 RPM	220-600 RPM	210-550 RPM				
✓	✓	✓	✓	✓			✓	Allows thread cutting
✓	✓	✓	✓	✓				Overheating protection
✓	✓	✓	✓	✓				Magnet adhesion indicator
✓	✓		✓	✓				Shuts down motor if magnetic contact lost
Quick-change keyless	Quick-change keyless	Set Screw	Quick-change keyless	Set Screw	Set Screw	Set Screw	Set Screw	
MT2	MT3	MT3	MT3	MT4			MT3	
		✓	✓	✓				
	✓	✓	✓	✓				
✓	✓	✓	✓					Swivel/adjustable base
6-5/8" x 3-1/3"	7-1/8" x 3-1/2"	8-11/16" x 8-11/16"	8-5/8" x 4-1/3"	14" x 4-3/4"	8-3/4" x 3-1/2"	7-1/4" x 3"	11-11/16" x 4"	

MABasic 200



Cutter capacity
1 3/8" dia.

Heavy-duty, purpose-built, single-speed workhorse

Powerful • Reliable

- Strong 8.2 Amp motor
- Compact, lightweight and portable – 12-1/4" high, 27 lbs.

Drill up to 1-3/8" dia.

- Uses annular cutters up to 1-3/8" dia.; 6-1/3" stroke
- Twist drilling capacity up to 1/2" dia.
- 3-1/3" stroke with included geared chuck
- Internal lubrication system



With included 1/2" geared chuck (IBC 18), this model easily converts to a standard drill press with a 3 1/3" stroke for conventional twist drills.

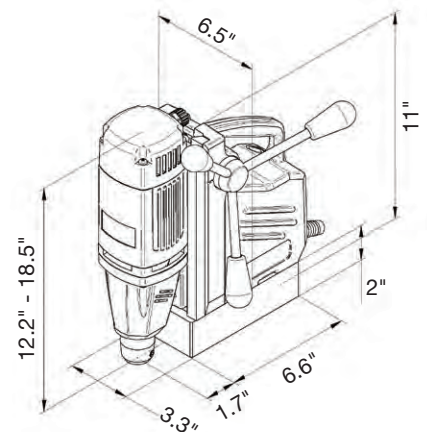

Equipped with Electronic Safety Shutoff Sensor (see p. 25)



Standard Equipment includes lubrication bottle, 3/4" weldon arbor, 1/2" geared chuck, safety strap, carabin hook, allen keys, pilot pin and carrying case.



MABasic 200 Specifications

Motor Power	8.2 Amp / 110 Volt
Weight	27 lbs.
Hole Capacity	1 3/8" dia.
Twist Drill Capacity	1/2" dia.
Speed	450 RPM
Magnet Base Size	6 5/8" L x 3 1/3" W
Dimensions	12 1/4" H x 9" L x 6 1/2" W
Magnetic Force (1" plate)	3080 lbs.
Arbor Bore	3/4" Weldon Shank
Internal Lubrication	Oil Bottle Included

➤ Annular Cutters: pages 54-64 ➤ Accessories: pages 65-71

MABasic 400



Two gears – powerful and reliable

Powerful • Reliable

- 9.5 Amp double-insulated motor
- 3/4" direct arbor

Drill up to 1-5/8" dia.

- Uses annular cutters up to 1-5/8" dia.
- Twist drilling capacity up to 5/8" dia.
- 3-1/3" stroke with chuck
- Internal lubrication system
- Compact and lightweight



With included 1/2" geared chuck (IBC 18), the MABasic 400 easily converts to standard drill press with a 3 1/3" stroke for conventional twist drills.

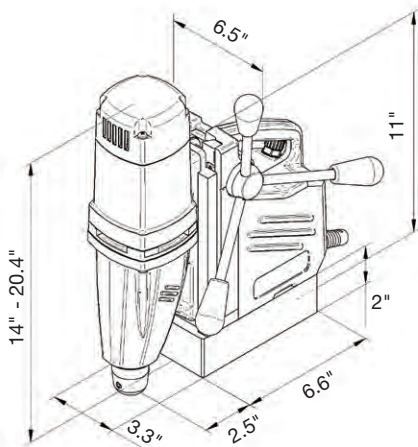

Equipped with Electronic Safety Shutoff Sensor (see p. 25)



MABasic 400 Specifications

Motor Power	9.5 Amp / 110 Volt
Weight	27 lbs.
Hole Capacity	1 5/8" dia.
Twist Drill Capacity	5/8" dia.
Speed	430 / 760 RPM (2 gears)
Magnet Base Size	6 5/8" L x 3 1/3" W
Dimensions	14" H x 9 1/2" L x 6 1/2" W
Magnetic Force (1" plate)	3080 lbs.
Arbor Bore	3/4" Weldon Shank
Internal Lubrication	Oil Bottle Included



Standard Equipment includes lubrication bottle, 3/4" weldon arbor, 1/2" geared chuck, safety strap, carabin hook, allen keys, pilot pin and carrying case.



➤ Annular Cutters: pages 54-64 ➤ Accessories: pages 65-71

MABasic 450



Cutter capacity
1 3/4" dia.

Professional-grade, two-speed versatility

Powerful • Reliable

- 10.5 Amp double-insulated motor
- MT2 – 3/4" direct arbor with automatic cooling

Drill up to 1-3/4" dia.

- Uses annular cutters up to 1-3/4" dia.
- Twist drilling capacity up to 3/4" dia.
- Internal lubrication system
- Compact and lightweight



With included 3/4" geared chuck (IBC 22), the MABasic 450 easily converts to standard drill press for conventional twist drills.

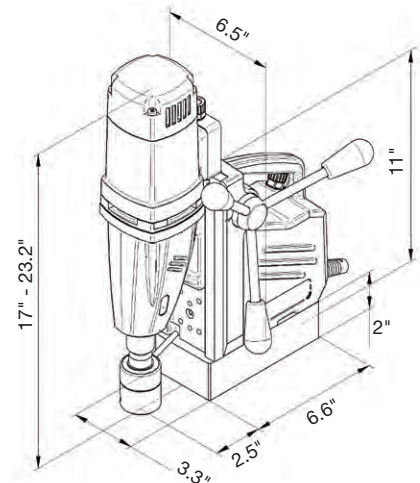

Equipped with Electronic Safety Shutoff Sensor (see p. 25)



MABasic 450 Specifications

Motor Power	10.5 Amp / 110 Volt
Weight	29 lbs.
Hole Capacity	1 3/4" dia.
Twist Drill Capacity	3/4" dia.
Speed	250 / 450 RPM (2 gears)
Magnet Base Size	6 5/8" L x 3 1/3" W
Dimensions	17" H x 9 1/2" L x 6 1/2" W
Magnetic Force (1" plate)	3080 lbs.
Arbor Bore	3/4" Weldon Shank
Spindle	MT2
Internal Lubrication	Oil Bottle Included

Standard Equipment

includes lubrication bottle, 3/4" geared chuck, safety strap, carabin hook, allen keys, pilot pin and carrying case.



➤ Annular Cutters: pages 54-64 ➤ Accessories: pages 65-71

MABasic 850



4-gear, powerful motor for demanding jobs

Powerful • Reliable

- 16 Amp double-insulated motor
- MT3 – 3/4" direct arbor with automatic cooling
- 19-3/8" high, 53 lbs.
- High-speed, 4-speed gearbox

Drill up to 3-1/16" dia.

- Uses annular cutters up to 3-1/16"; 10" stroke
- Twist drilling capacity up to 1-1/4" dia.
- Internal lubrication system



With included 3/4" chuck (IBC 21), this model easily converts to a standard drill press for conventional twist drills.

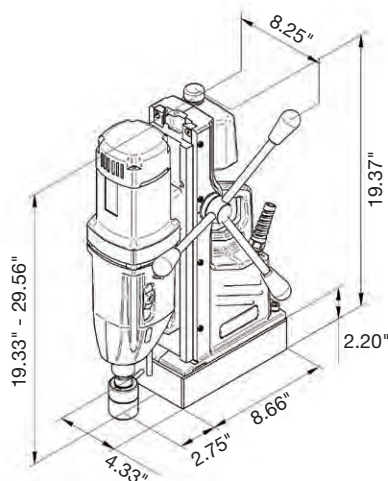

MABasic 850 Specifications

Motor Power	16 Amp / 110 Volt
Weight	53 lbs.
Hole Capacity	3 1/16" dia.*
Twist Drill Capacity	1 1/4" dia.
Speed	1: 110 RPM, 2: 175 RPM 3: 245 RPM, 4: 385 RPM
Magnet Base Size	8 5/8" L x 4 1/3" W
Dimensions	19 3/8" H x 11 5/8" L x 8 1/4" W
Magnetic Force (1" plate)	6000 lbs.
Arbor Bore	3/4" Weldon Shank
Spindle	MT3
Internal Lubrication	Included

* 3-1/16" cutters have 1-1/4" Weldon shank. Part No. ZIA 30/32 arbor is required.

Standard Equipment includes 3/4" geared chuck, safety strap, carabin hook, allen keys, pilot pin and carrying case.



➤ [Annular Cutters: pages 54-64](#) ➤ [Accessories: pages 65-71](#)

MAB 155



Cutter capacity
1 1/2" dia.

Horizontal motor mount for drilling in tight spaces

Powerful • Reliable

- 9.25 Amp double-insulated motor
- Ultra compact, 7" high
- Ratchet-style advancing mechanism for work in spaces with limited clearance
- Lightweight, 24 lbs.
- Intelligent electronic torque control
- Designed for continuous use

Drill up to 1-1/2" dia.*

- Uses annular cutters up to 1-1/2" dia.

Integrated Safety

- Emergency-off function
- Internal cable routing
- Simple, ergonomic arrangement of controls for one-handed operation

Internal cable routing protects the motor power cord from external damage



Ratchet-style advancing mechanism for work in spaces with limited clearance.

Equipped with Electronic Safety Shutoff Sensor (see p. 25)

MAB 155 uses standard 3/4" shank annular cutters



Cutter Capacity



ø 1 1/2"

Stroke (length)



1 1/2"

Speed Range (RPM)



460

* Model MAB 155 accepts cutters with a 3/4" weldon shank and a maximum depth of cut of 1-1/2".

Switches for power and magnet adhesion are arranged for simple, uncomplicated operation.



MAB 155 Specifications

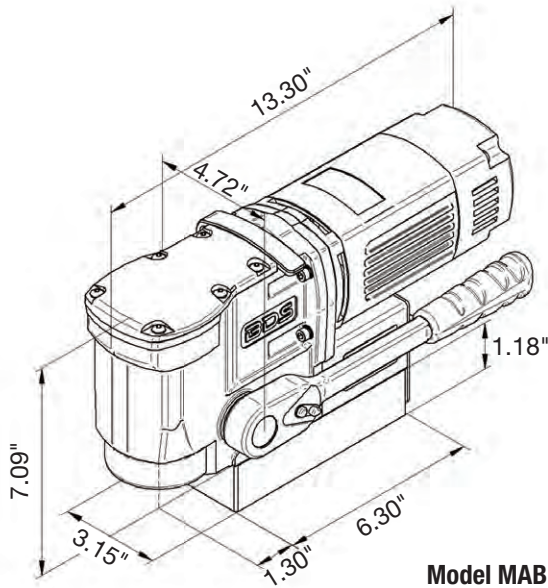

Model MAB 155

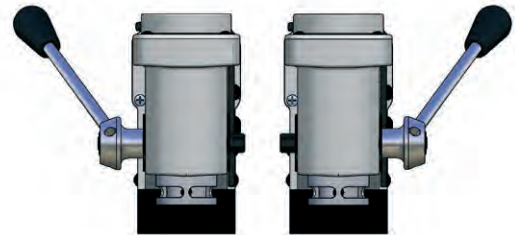

Advancing lever can be mounted on either the left or right side of the MAB 155.

MABasic 155 Specifications

Motor Power	9.25 Amp / 110 Volt
Weight	24 lbs.
Hole Capacity	1 1/2" dia.
Speed	460 RPM
Magnet Base Size	6 ⁵ / ₁₆ " L x 3 ³ / ₁₆ " W
Dimensions	7 ¹ / ₈ " H x 13 ⁵ / ₁₆ " L x 4 ³ / ₄ " W
Magnetic Force (1" plate)	2640 lbs.
Arbor Bore	3/4" Weldon Shank

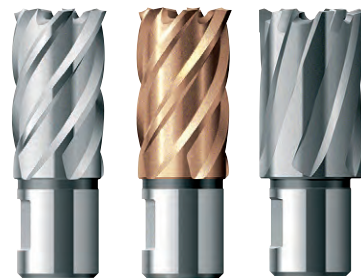

Model MAB 155 accepts cutters with 3/4" weldon shank. This unit has a maximum depth of cut of 1-1/2".

See pages 56-61 for our HSS, TiAIN and Carbide-tipped cutters.

Standard Equipment

- 1 Magnetic drilling machine
- 1 Pilot pin
- 1 Plastic carrying case
- 1 Safety chain
- 1 Hexagon socket screw key SW 4
- 1 Operating manual
- 1 Warranty certificate



Standard Equipment also includes safety strap, carabin hook and allen keys.



AutoMAB 350



Cutter capacity
1 1/2" dia.

Compact drill with automatic feed – forward and reverse



Powerful • Reliable

- 10.5 Amp double-insulated motor
- Designed for continuous use
- Lightweight, 33 lbs.
- Automatic feed with auto stop and retraction
- Power feed automatically controls drill pressure to maintain optimal RPM and feed rate

Drill up to 1-1/2" dia.

- Uses annular cutters up to 1-1/2" dia.
- Twist drilling capacity up to 1/2" dia.
- 6" stroke, 3-1/3" stroke with chuck
- Integrated cutting oil reservoir
- Automatic internal lubrication

Integrated Safety

- Simple, ergonomic arrangement of controls for one-handed operation



With optional 1/2" geared chuck (IBC 18), this model easily converts to a standard drill press with a 3 1/3" stroke for conventional twist drills.

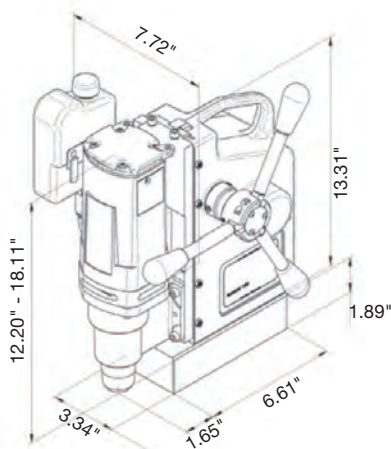

Model AutoMAB 350 Specifications

Motor Power	10.5 Amp / 110 Volt
Weight	33 lbs.
Hole Capacity	1 1/2" dia.
Drilling Depth	2-3/8" with pilot pin 4-3/8" without pilot pin
Speed	460 RPM
Magnet Base Size	6 5/8" L x 3 1/3" W
Dimensions	12 1/4" H x 8 3/4" L x 7 3/4" W
Magnetic Force (1" plate)	3750 lbs.
Arbor Bore	3/4" Weldon Shank
Automatic Lubrication	Included
Spindle	-

Standard Equipment includes auto lubrication, safety strap, carabin hook, allen keys and steel carrying case.[†]

[†] Steel case intended mainly for shipping purposes; damage may occur in transit.

➤ Annular Cutters: pages 54-64 ➤ Accessories: pages 65-71

AutoMAB 450



Cutter capacity
2" dia.



Powerful • Reliable

- 10.5 Amp double-insulated motor
- Designed for continuous use
- Lightweight, 33 lbs.
- Automatic feed with auto stop and retraction
- Power feed automatically controls drill pressure to maintain optimal RPM and feed rate

Drill up to 2" dia.*

- Uses annular cutters up to 2" dia. (*with TCT Carbide cutters, 1-3/4" dia. with all other annular cutters)
- Twist drilling capacity up to 3/4" dia.
- 6" stroke, 3-1/3" stroke with chuck
- Integrated cutting oil reservoir
- Automatic internal lubrication

Integrated Safety

- Simple, ergonomic arrangement of controls for one-handed operation



With an optional 1/2" chuck (Part No. IBC 18), the AutoMAB 450 easily converts to a standard drill press for conventional twist drills. An optional 3/4" geared chuck is also available (Part No. IBC 22).

Model AutoMAB 450 Specifications

Motor Power	10.5 Amp / 110 Volt
Weight	35 ¹ / ₄ lbs.
Hole Capacity	2" dia.*
Drilling Depth	2-3/8" with pilot pin 4-3/8" without pilot pin
Speed	250 / 450 RPM (2 gears)
Magnet Base Size	6 ⁵ / ₈ " L x 3 ¹ / ₃ " W
Dimensions	16 ⁷ / ₈ " H x 9 ¹ / ₈ " L x 7 ³ / ₄ " W
Magnetic Force (1" plate)	3750 lbs.
Arbor Bore	3/4" Weldon Shank
Automatic Lubrication	Included
Spindle	MT2

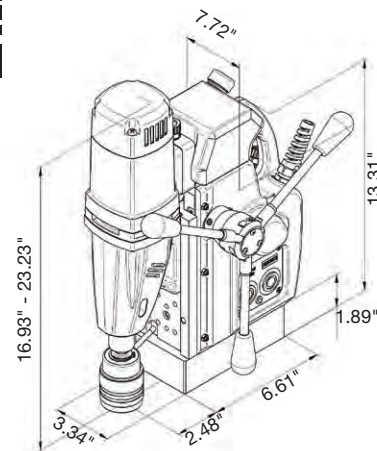

Standard Equipment includes auto lubrication, safety strap, carabin hook, MT2 drift key, allen keys and steel carrying case.†

† Steel case intended mainly for shipping purposes; damage may occur in transit.

* 2" dia. with TCT Annular Cutters; 1-3/4" capacity with all other annular cutters

➤ **Annular Cutters:** pages 54-64 ➤ **Accessories:** pages 65-71

MAB 465

Cutter capacity
2" dia.

Reversible motor ideal for tapping and twist drilling



Powerful • Reliable

- 10.5 Amp double-insulated motor
- 14-1/8" high, 29 lbs.
- High-speed, variable-speed oilbath gearbox, ideal for annular cutters and twist drills
- Designed for continuous use

Drill up to 2" dia. Tap up to 5/8" dia.

- Uses annular cutters up to 2"* dia.
- Twist drilling capacity up to 5/8" dia.
- Tapping capacity up to 5/8" dia.
- Integrated cutting oil reservoir
- Automatic internal lubrication

Integrated Safety

- Green/Red LED magnetic force indicator for safe operation
- Internal cable routing
- Simple, ergonomic arrangement of controls for one-handed operation
- Emergency-off function

Equipped with Electronic
Safety Shutoff Sensor (see p. 25)

* 2" with TCT Annular Cutters;
1-5/8" capacity with all other cutters

REVERSIBLE







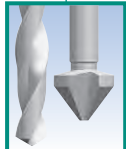

Internal
cable routing
protects the motor
power cord from
external damage

Optional Geared Chucks

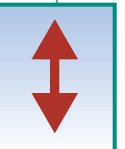
With an optional 1/2" geared chuck (Part No. IBC 18), this model easily converts to a standard drill press with a 5" stroke for conventional twist drills.

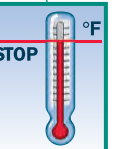
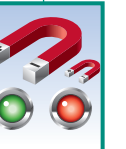

Cutter Capacity	Twist Drill / Countersink	Tap	Stroke (length)	2-gear Variable Speed (RPM)	Electronics	Overheat Protection	Magnet Force Indicator	Reversible (CW/CCW)
								
Ø 2"	Ø 5/8" / Ø 1 1/2"	Ø 5/8"	6 1/3"	50-250 100-450	Variable-speed Control	CoolMag™	SafeMag™	

➤ Annular Cutters: pages 54-64 ➤ Accessories: pages 65-71

MAB 465 Specifications



Model MAB 465

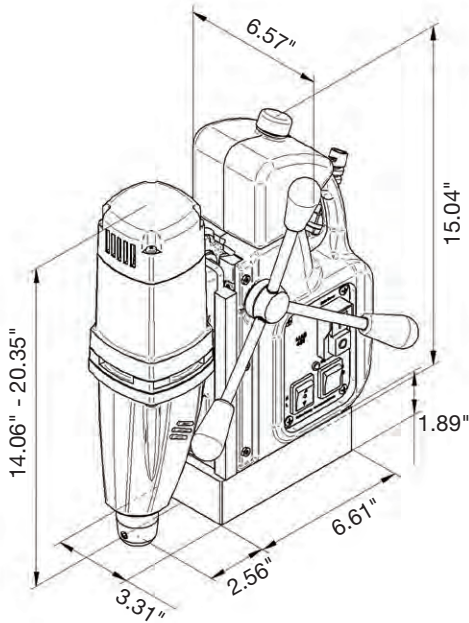

MABasic 465 Specifications

Motor Power	9.5 Amp / 110 Volt
Weight	29 lbs.
Hole Capacity	2" dia.
Twist Drill Capacity	5/8" dia.
Speed	50-250 and 100-450 RPM
Magnet Base Size	6 ⁵ / ₈ " L x 3 ¹ / ₃ " W
Dimensions	14 ¹ / ₈ " H x 9 ⁵ / ₈ " L x 6 ¹ / ₂ " W
Magnetic Force (1" plate)	3750 lbs.
Arbor Bore	3/4" Weldon Shank
Automatic Lubrication	Included



* 2" with TCT Annular Cutters; 1-5/8" capacity with all other cutters

Standard Equipment

- 1 Magnetic drilling machine
- 1 Manual arbor with set screws, Weldon 3/4"
- 2 Pilot pins - 1" and 2" depth
- 1 Safety chain
- 1 Warranty certificate

Standard Equipment

also includes molded plastic carrying case, operating manual, auto lubrication, safety strap and allen keys.

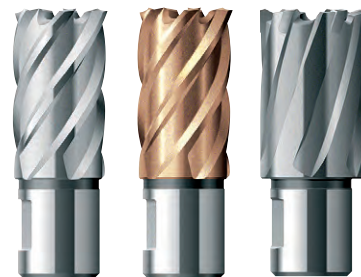

See pages 56-61 for our HSS, TiAIN and Carbide-tipped cutters.



➤ Annular Cutters: pages 54-64 ➤ Accessories: pages 65-71



Cutter capacity
2 1/16" dia.

MAB 485 & MAB 485 SB



Versatile for workshop and assembly applications



Powerful • Reliable

- 10.5 Amp double-insulated motor
- 17-1/4" high, 29 lbs.
- High-speed, variable-speed oilbath gearbox, ideal for annular cutters and twist drills
- Designed for continuous use
- Intelligent electronic torque control

Drill up to 2-1/16" dia. Tap up to 15/16" dia.

- Uses annular cutters up to 2-1/6" dia.
- Twist drilling capacity up to 7/8" dia.
- Tapping capacity 3/16" to 15/16" dia.
- Integrated cutting oil reservoir
- Automatic internal lubrication
- Swivel base (model MAB 485 SB)

Keyless Cutter Mount

- Quick-change keyless cutter system for 3/4" Weldon shank, standard
- Also includes manual arbor for 3/4" Weldon shank (MT2) with set screws



Integrated Safety

- Green/Red LED magnetic force indicator for safe operation
- Internal cable routing
- Simple, ergonomic arrangement of controls for one-handed operation
- Emergency-off function

Internal cable routing protects the motor power cord from external damage

Equipped with Electronic Safety Shutoff Sensor (see p. 25)



With included 3/4" chuck (IBC 22), this model easily converts to a standard drill press for conventional twist drills.

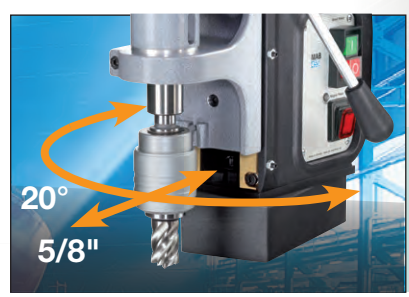

Model MAB 485 SB features a swivel base providing 20° movement left and right and 5/8" forward and backward.

Cutter Capacity	Twist Drill / Countersink	Ream / Tap	Stroke (length)	2-gear Variable Speed (RPM)	Electronics	Overheat Protection	Magnet Force Indicator	Reversible (CW/CCW)
$\varnothing 2\frac{1}{16}$	$\varnothing 7/8'' / \varnothing 1\frac{5}{8}$	$\varnothing 7/8'' / \varnothing 15/16''$	6 1/3"	50-250 100-450	Variable-speed Control	CoolMag™	SafeMag™	

➤ Annular Cutters: pages 54-64 ➤ Accessories: pages 65-71

MAB 485 & MAB 485 SB Specifications

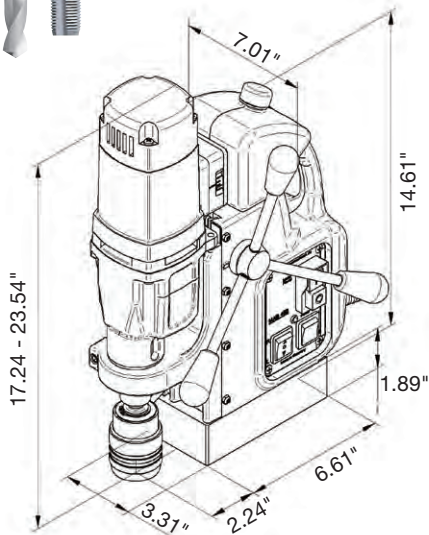

Model MAB 485 & MAB 485 SB



Model MAB 485 Specifications

Motor Power	10.5 Amp / 110 Volt
Weight	29 lbs.
Hole Capacity	2 ¹ / ₁₆ " dia.
Twist Drill Capacity	7/8" dia.
Speed	50-250 and 100-450 RPM
Magnet Base Size	6 ⁵ / ₈ " L x 3 ¹ / ₃ " W
Dimensions	17 ¹ / ₄ " H x 11 ⁵ / ₈ " L x 7" W
Magnetic Force (1" plate)	3750 lbs.
Arbor Bore	3/4" Weldon Shank
Spindle	MT2
Automatic Lubrication	Included
Swivel Base	Order MAB 485 SB



Shown with optional Pipe Saddle Clamp System for safe, secure drilling of pipes and tubular material. See page 71 for details.

Standard Equipment

- 1 Magnetic drilling machine
- 1 Quick-change arbor system
KEYLESS Weldon 3/4"
- 1 Manual arbor with set screws, Weldon 3/4", MT2
- 1 Geared chuck, 3/4"
- 2 Pilot pins - 1" and 2" depth
- 1 Safety chain
- 1 Drift key MT2
- Tap collet adapters - 1/4", 3/8", 1/2" and 3/4"
- 1 Warranty certificate

Standard Equipment also includes molded plastic carrying case, operating manual, auto lubrication, safety strap, carabin hook and allen keys.





MAB 525 & MAB 525 SB



High power, ideal for production use



Powerful • Reliable

- 14.5 Amp double-insulated motor
- 19" high, 35 lbs.
- High-speed, 2-speed oilbath gearbox, ideal for annular cutters and twist drills
- Designed for continuous use
- Intelligent electronic torque control

Drill up to 2-1/2" dia. Tap up to 15/16" dia.

- Uses annular cutters up to 2-1/2" dia.
- Twist drilling capacity up to 1" dia.
- Tapping capacity up to 15/16" dia.
- Integrated cutting oil reservoir
- Automatic internal lubrication
- Swivel base (model MAB 525 SB)

Keyless Cutter Mount

- Quick-change keyless cutter system for 3/4" Weldon shank
- Also includes manual arbor for 3/4" Weldon shank (MT3) with set screws

Integrated Safety

- Green/Red LED magnetic force indicator for safe operation
- Internal cable routing
- Simple, ergonomic arrangement of controls for one-handed operation
- Emergency-off function



REVERSIBLE

Internal cable routing protects the motor power cord from external damage







Equipped with Electronic Safety Shutoff Sensor (see p. 25)

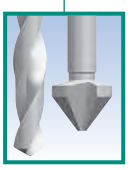

With the included 3/4" chuck (Part No. IBC 21), this model easily converts to a standard drill press with a 5" stroke for conventional twist drills.

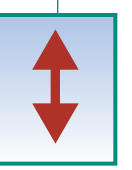

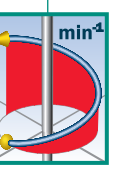
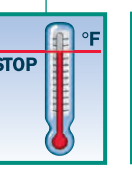
Model MAB 525 SB features a swivel base providing 20° movement left and right and 5/8" forward and backward.

Cutter Capacity	Twist Drill / Countersink	Ream / Tap	Stroke (length)	2-gear Variable Speed (RPM)	Electronics	Overheat Protection	Magnet Force Indicator	Reversible (CW/CCW)
 ø 2 1/2"	 ø 1" / ø 2"	 ø 7/8" / ø 15/16"	 6 1/3"	 70-280 180-580	 Variable-speed Control	 CoolMag™	 SafeMag™	

➤ Annular Cutters: pages 54-64 ➤ Accessories: pages 65-71

MAB 525 & MAB 525 SB Specifications

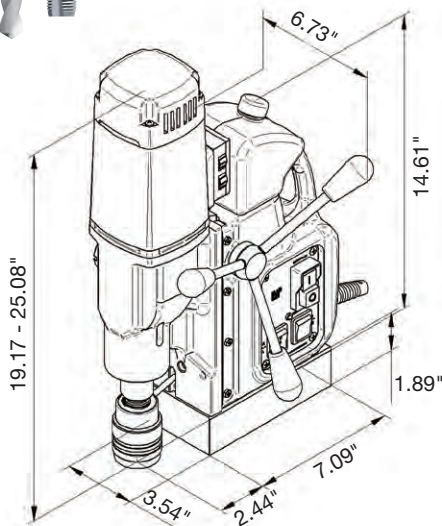

Model MAB 525
& MAB 525 SB



Model MAB 525 Specifications

Motor Power	14.5 Amp / 110 Volt
Weight	35 lbs.
Hole Capacity	2 1/2" dia.
Twist Drill Capacity	15/16" dia.
Speed	70-280 and 180-580 RPM
Magnet Base Size	7 1/8" L x 3 1/2" W
Dimensions	19" H x 11 3/4" L x 6 3/4" W
Magnetic Force (1" plate)	4500 lbs.
Arbor Bore	3/4" Weldon Shank
Spindle	MT3
Automatic Lubrication	Included
Swivel Base	Order MAB 525 SB



Standard Equipment

- 1 Magnetic drilling machine
- 1 Quick-change arbor system
KEYLESS Weldon 3/4"
- 1 Manual arbor with set screws,
Weldon 3/4", MT3
- 1 Geared chuck, 3/4"
- 2 Pilot pins - 1" and 2" depth
- 1 Safety chain
- 1 Drift key MT3
- Tap collet adapters - 1/4", 3/8", 1/2" and 3/4"
- 1 Warranty certificate



Standard Equipment
also includes
molded plastic
carrying case,
operating manual,
auto lubrication,
safety strap,
carabin hook and
allen keys.

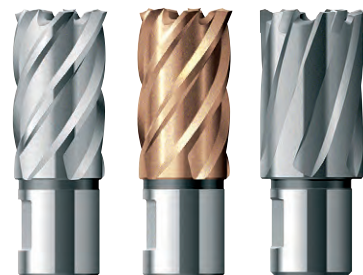

See pages 56-61 for our HSS, TiAIN
and Carbide-tipped cutters.



➤ Annular Cutters: pages 54-64 ➤ Accessories: pages 65-71

MAB 825 KTS



Versatile machine with adjustable X and Y positioning

Powerful • Reliable

- 16 Amp double-insulated motor
- 4-speed oilbath gearbox for applications requiring high power
- Designed for continuous use
- Infinitely variable torque control and full-wave control electronics
- Ideal for drilling, boring and slotting applications
- Includes servo-assisted drilling feature to help maintain feed pressure during operation

Drill up to 3-1/8" dia. Tap up to 1-3/16" dia.





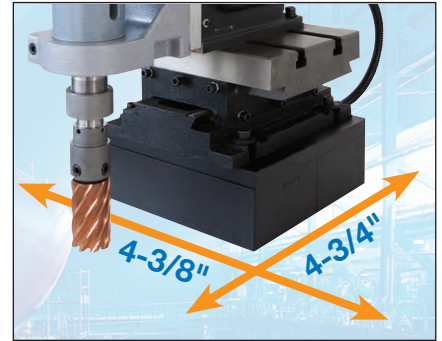

- Multi-axis positioning
- Uses annular cutters up to 3-1/8" dia.
- Twist drilling capacity up to 1-1/4" dia.
- 10" stroke
- Integrated cutting oil reservoir
- Automatic internal lubrication

Integrated Safety

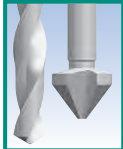
- Simple, ergonomic arrangement of controls for one-handed operation
- Emergency-off function

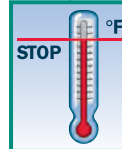

Model MAB 825 KTS features multi-axis positioning, allowing the drill to be adjusted up to 4-3/4" forward/backward and up to 4-3/8" left/right after magnet is adhered to surface. Ideal for job site drilling, boring and slotting applications where dismantling is not feasible.

Cutter Capacity	Twist Drill / Countersink	Ream / Tap	Stroke (length)	4-gear Variable Speed (RPM)	Electronics	Overheat Protection	Magnet Force Indicator	Reversible (CW/CCW)
 Ø 3 1/8"	 Ø 1 1/4" / 1 37/64"	 Ø 1 1/4" / Ø 1 1/4"	 10"	 40-110, 65-175, 140-360, 220-600	 Variable-speed Control	 CoolMag™	 SafeMag™	

➤ Annular Cutters: pages 54-64 ➤ Accessories: pages 65-71

MAB 825 KTS

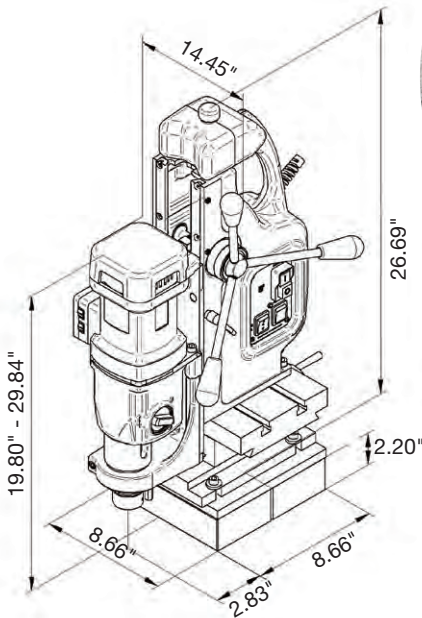
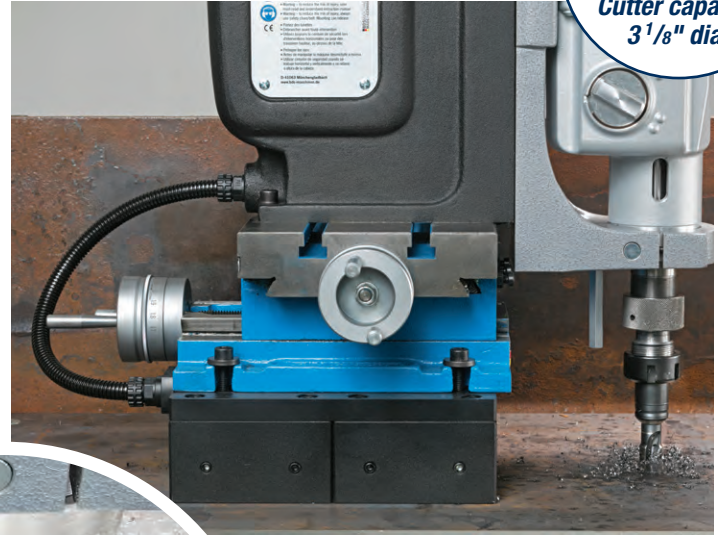

Chuck Collet Tool Holder Set with Case

Part No. ZSF 316 (included) can hold most standard end mills with shanks from 1/8" to 5/8" dia. (3mm to 16mm dia.). Kit includes:

- MT3 collet holder with threaded adapter piece
- 15 collets for shank diameters 1/8" to 5/8" (3 to 16mm)
- 2 collet tightening spanner wrenches



Model MAB 825 KTS Specifications

Motor Power	16 Amp / 110 Volt
Weight	99 lbs.
Hole Capacity	3 1/8" dia.
Twist Drill Capacity	1 1/4" dia.
Tapping Capacity	1 3/16" dia.
Speed	40-110, 65-175 140-360, 220-600 RPM
Magnet Base Size	8 11/16" L x 8 11/16" W
Dimensions	19 3/4" H x 13" L x 14 1/2" W
Magnetic Force (1" plate)	6600 lbs.
Arbor Bore	3/4" and 1 1/4", standard
Spindle	MT3
Automatic Lubrication	Included



Standard Equipment

- 1 Magnetic drilling machine
- 1 Chuck collet tool holder set
- 1 Steel carrying case†
- 1 Safety chain
- 1 Operating manual
- 1 Warranty certificate

Standard Equipment also includes auto lubrication, safety strap, carabin hook and allen keys.

† Steel case intended mainly for shipping purposes; damage may occur in transit.

Optional 3/4" geared chucks available (Part No. IBC 21)

➤ [Annular Cutters: pages 54-64](#) ➤ [Accessories: pages 65-71](#)

MAB 825 & MAB 845

Cutter capacity
4 1/16" dia.

Ideal for steel engineering, plant construction and more



REVERSIBLE

Powerful • Reliable

- 16 Amp double-insulated motor
- 4-speed oilbath gearbox for applications requiring high power
- Designed for continuous use
- Infinitely variable torque control and full-wave control electronics

**Drill up to 4-1/16" dia.
Tap up to 1-1/8" dia.**

- Uses annular cutters up to 4-1/16" dia.
- Twist drilling and reaming capacities up to 1-1/4" dia.
- Tapping capacity up to 1-1/8" dia.
- Integrated cutting oil reservoir
- Automatic internal lubrication
- Automatic feed (model MAB 825 V), ideal for production applications
- Swivel base (model MAB 845)

Keyless Cutter Mount

- Quick-change keyless cutter system for 3/4" Weldon shank
- Arbor for 1-1/4" Weldon shank
- Also includes manual arbor for 3/4" Weldon shank (MT3) with set screws

Integrated Safety

- Green/Red LED magnetic force indicator for safe operation
- Internal cable routing
- Simple, ergonomic arrangement of controls for one-handed operation
- Emergency-off function



Internal cable routing protects the motor power cord from external damage

Equipped with Electronic Safety Shutoff Sensor (see p. 25)

4 Gears with Variable Speed



Twist Drilling



Tapping



Reaming



Countersinking

MAB 825

Standard model with 16 Amp motor

MAB 825 V

Includes automatic feed - ideal for production applications

MAB 845

Includes 30° movement left and right and 3/4" forward and backward

See pages 49 and 68 for Tap Holders and Accessories

Cutter Capacity

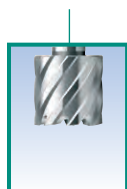

ø 4 1/16"

Twist Drill / Countersink

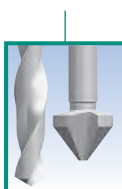

ø 1 1/4" / ø 2"

Ream / Tap

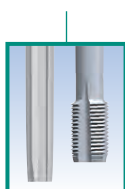

ø 1 1/4" / ø 1 1/8"

Stroke (length)



10"

4-gear Variable Speed (RPM)



40-110
65-175
140-360
220-600

Electronics



Variable-speed Control

Overheat Protection

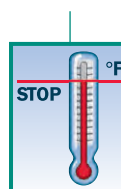

CoolMag™

Magnet Force Indicator



SafeMag™

Reversible (CW/CCW)



➤ Annular Cutters: pages 54-64 ➤ Accessories: pages 65-71

MAB 825 & MAB 845 Specifications



Cutter capacity
4 1/16" dia.

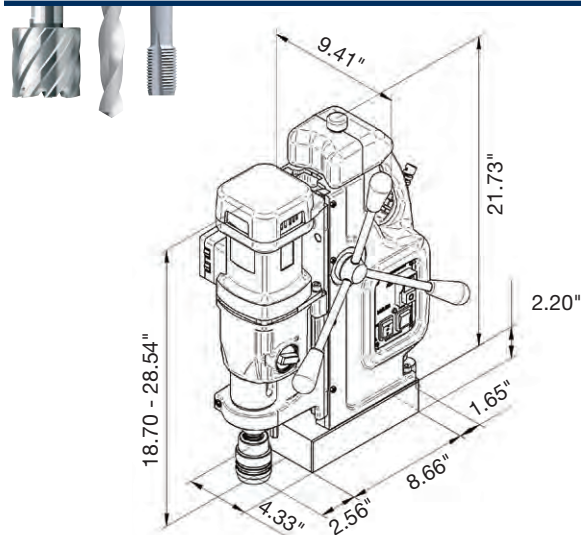

Model MAB 825, 825 V & 845



With an optional 3/4" geared chuck (Part No. IBC 21), this model easily converts to a standard drill press for conventional twist drills.



Model MAB 825 & 845 Specifications

Motor Power	16 Amp / 110 Volt
Weight	55 lbs.
Hole Capacity	4 1/16" dia.
Twist Drill Capacity	1 1/4" dia.
Tapping Capacity	1 1/8" dia.
Speed	40-110, 65-175, 140-360, 220-600 RPM
Magnet Base Size	8 5/8" L x 4 1/3" W
Dimensions	18 5/8" H x 14 7/16" L x 9 7/16" W
Magnetic Force (1" plate)	6600 lbs.
Arbor Bore	3/4" and 1 1/4", standard
Spindle	MT3
Automatic Lubrication	Included
Automatic Feed	Order MAB 825 V
Swivel Base	Order MAB 845



Model MAB 845 features a swivel base providing 30° movement left and right and 3/4" forward and backward.

Standard Equipment

- 1 Magnetic drilling machine
- 1 Quick-change arbor system KEYLESS Weldon 3/4"
- 1 Manual arbor with set screws, Weldon 3/4", MT3
- 1 Arbor 1 1/4" Weldon, MT3*
- 4 Pilot pins - 1", 2", 3" and 4" depth
- 1 Safety chain
- 1 Hexagon socket screw key SW 6
- 1 Drift key MT3
- 1 Warranty certificate
- 1 Carrying case**

Standard Equipment also includes operating manual, auto lubrication, safety strap, carabin hook and allen keys.



* Optional accessory for MAB 825 V
** Not available for MAB 825 V

Rolling Transport Case

Robust transport case with wheels, carrying handle and sturdy closures. Included with MAB 825/845 – protect your drill from water and dust with this rugged case. (Part No. ZHK 825)



➤ Annular Cutters: pages 54-64 ➤ Accessories: pages 65-71



MAB 1300

Large holes – up to 5 1/8" diameter
Tapping up to 1 5/8" diameter



4 Gears with Variable Speed



Twist Drilling



Tapping



Reaming



Countersinking



Optional Special-Purpose Cutting Tool

Powerful • Reliable

- 20 Amp double-insulated motor
- 22" high, 112 lbs.
- 4-speed oilbath gearbox for applications requiring high power
- Designed for continuous use
- Infinitely variable torque control and full-wave control electronics

Drill up to 5-1/8" dia.
Tap up to 1-5/8" dia.

- Uses annular cutters 7/16" to 5-1/8" dia., 1" and 2" depth 7/16" to 5-1/8" dia., 3" to 8" depth*
- Twist drilling up to 1-3/4" - uses MT4, countersinking up to 3" dia.
- Tapping up to 1-5/8"
- Reaming up to 2"
- Automatic internal lubrication

Integrated Safety

- Green/Red LED magnetic force indicator for safe operation
- Equipped with Electronic Safety Shutoff Sensor
- Emergency-off function







Ideal for use with TCT Carbide cutters up to 5 1/8" dia. – see pages 60-61.



* 3" depth cutters or longer require purchase of ZIA 432 KN adapter.

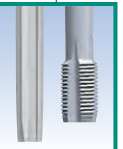
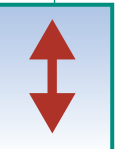

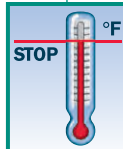
Equipped with Electronic Safety Shutoff Sensor (see p. 25)

Cutter Capacity	Twist Drill / Countersink	Ream / Tap	Stroke (length)	4-gear Variable Speed (RPM)	Electronics	Overheat Protection	Magnet Force Indicator	Reversible (CW/CCW)
 ø 5 1/8"	 ø 1 3/4" / ø 3"	 ø 2" / ø 1 5/8"	 3.35" (12" without retainer)	 30-80 50-120 130-350 210-550	 Variable-speed Control	 CoolMag™	 SafeMag™	

➤ *Annular Cutters: pages 54-64* ➤ *Accessories: pages 65-71*

MAB 1300 Specifications

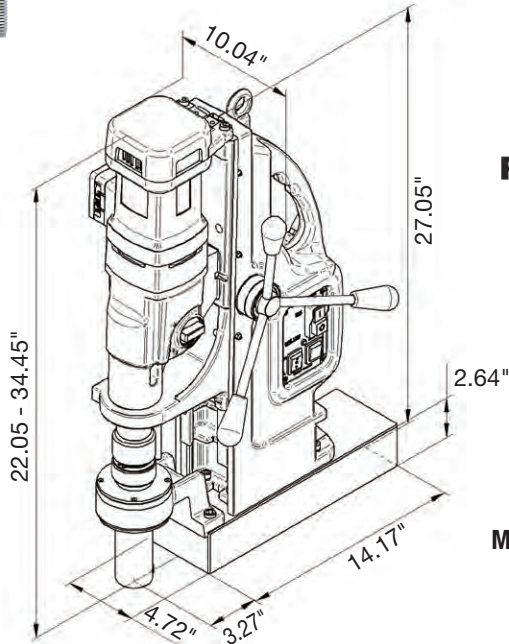

Model MAB 1300



Model MAB 1300 Specifications

Motor Power	20 Amp / 110 Volt
Weight	112 lbs.
Hole Capacity	5 1/8" dia.**
Twist Drill Capacity	1 3/4" dia.
Tapping Capacity	1 5/8" dia.
Speed	30-80, 50-120, 130-350, 210-550 RPM
Magnet Base Size	14" L x 4 3/4" W
Dimensions	22" H x 19 1/2" L x 10" W
Magnetic Force (1" plate)	23,600 lbs.
Arbor Bore	1 1/4" (3/4" adapter included)
Spindle	MT4
Automatic Lubrication	Included



** Maximum hole diameter is with TCT Carbide cutters - see p. 60-61

Standard Equipment

- 1 Magnetic drilling machine
- 1 Carrying case on wheels
- 1 Arbor adapter to 3/4" Weldon
- 1 Safety chain
- 1 Hexagon socket screw key SW 6
- 1 Drift key MT4
- 1 Operating manual
- 1 Warranty certificate



Standard Equipment also includes auto lubrication, safety strap, carabin hook and allen keys.

Accessories

See pages 48-49 for tapping accessories and wheeled carrying case.





MAB 1300 V

Strongest magnetic drill with adjustable automatic feed and reverse

- Ideal for production applications
- Power feed controls drill pressure to maintain optimal RPM and feed rate

Drill up to 5-1/8" dia.
Tap up to 1-5/8" dia.
Ream up to 2" dia.



Drill automatically



Drill manually

Automatic feed motor

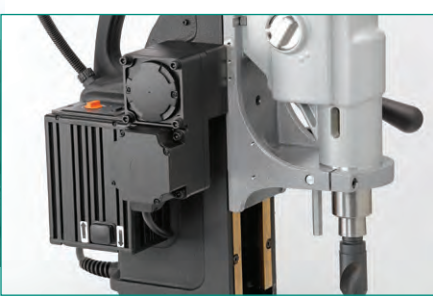

Rolling Transport Case for MAB 1300

Order No. **ZHK 1300**

Robust transport case with wheels, carrying handle and sturdy closures. Protect your investment from water and dust with this rugged case. Four large ABS locks and an interior configuration customized for machine to secure drill and accessories during transit. Lightweight, heavy-duty plastic construction and robust ABS wheels.

Drill not included with ZHK 1300. Purchase of MAB 1300 drill includes ZHK 1300 case. See page 45 for MAB 825/845 case.



Watertight, shock-proof and robust – the right protection for your machine.

Four large ABS locks secure the robust plastic case

Tapping Accessories for MAB 1300, MAB 825, MAB 845 and CSU 100/3RL



Heavy-duty Tap Holders

- Positive, accurate driving of larger-sized taps
- No slippage or tap damage
- Tap shank square engages with square drive socket
- 3 set screws secure tap in holder

Order Number	Morse Taper	Tap Size	Tap Shank Diameter	Tap Shank Square
70308	3	5/8"	.480	.366
70301	3	3/4"	.590	.442
70302	3	7/8"	.697	.523
70303	3	1"	.800	.600
70304	3	1-1/8"	.896	.672
70305	3	1-1/4"	1.02	.765
70307	3	1-1/2"	1.23	.925
70401	4	3/4"	.590	.442
70402	4	7/8"	.697	.523
70403	4	1"	.800	.600
70404	4	1-1/8"	.896	.672
70405	4	1-1/4"	1.021	.766
70406	4	1-3/8"	1.108	.831
70407	4	1-1/2"	1.233	.925
70408	4	1-5/8"	1.305	.979



Part No. **GSW 444** quick-change tapping chuck with MT4 connection (for MAB 1300). Collets not included. *GSW 444 and GSS.4xx collet set shown below.*

Order Number	Tap Collet	Shank Diameter	Square Drive
GSS.420	20mm	16mm	12mm
GSS.422	22mm	18mm	14.5mm
GSS.427	27mm	20mm	16mm
GSS.433	33mm	32mm	20mm
GSS.442	42mm	32mm	24mm



See page 68 for additional tapping options.



Tap Collets and Reducing Adapters

Tap Collets with 3/4" or 1-1/4" Weldon shank <i>all threads shown are ASA Standard (or DIN 376 for metric)</i>			
Thread	Order No.	Thread	Order No.
1/4	TCM 1/4	10mm	ZGA 010
5/16	TCM 5/16	12mm	ZGA 012
3/8	TCM 3/8	14mm	ZGA 014
7/16	TCM 7/16	16mm	ZGA 016
1/2	TCM 1/2	18mm	ZGA 018
9/16	TCM 9/16	20mm	ZGA 020
5/8	TCM 5/8	22mm	ZGA 022
11/16	TCM 11/16	24mm	ZGA 024
3/4	TCM 3/4	27mm	ZGA 027
1-1/4" Weldon shank:		1-1/4" Weldon shank:	
1	TCM 1	33mm	ZGA 033
1-1/4	TCM 1-1/4	42mm	ZGA 044

Bushing – Reduces 1-1/4" Weldon shank to 3/4" Weldon shank
Order No. **ZAP 200**



Reducing Sleeves
DIN 2185



Order No. **ZRH 320** for MT 3:2
(adapts MT3 to MT2)

Order No. **ZRH 430** for MT 4:3
(adapts MT4 to MT3)

Unibroach® Large-Hole Cutting

Cut holes up to 5-1/8" dia., 12" deep!

Available in TCT Carbide, HSS, Cobalt and ARMOR-PLATED Unibroach™



Drill perfect holes up to 5 1/8" diameter without runout

- Standard with 3/4" or 1 1/4" shank diameters
- More cutting teeth to distribute the load evenly – increase tool life and achieve faster feed rates
- Use on milling machines, drill presses, CNC and other equipment
- A solid slug has a higher value for scrap metal

* Pilot pins supplied with annular cutters up to 4" DOC. Other pilot pins can be purchased separately.





AIRBOR™ AB-4300

Motor and magnet are powered completely by compressed air

Pneumatic power for hazardous environments

ATEX Certified

Safe • Reliable

- Inherently safer than electromagnetic drills in hazardous atmospheres and wet environments where electricity requires "hot work permits"
- ATEX certified
- Industry's first completely air-operated magnetic drill – NO ELECTRICITY!
- Fail-safe permanent magnet is activated "on" and "off" by air pressure; in the event of a loss of air flow, the magnet will not disengage
- 1600 lbs. magnet holding strength

Drill up to 2-1/16" dia.

- Uses annular cutters up to 2-1/16" dia.
- Twist drilling capacity up to 5/8" dia.
- Powerful 1.6 HP drill motor
- Long drill stroke – up to 10 1/4"
- Pressurized coolant system lubricates cutter and reduces risk of sparking



Model AB-4300-2







With a geared chuck adapter (Part No. IBC 18) and extra rack (Model No. AB-4300-2R), AIRBOR™ easily converts to a standard drill press with a 7 1/2" stroke.



Pressurized lubrication system (Part No. 9 4002 0020 N)

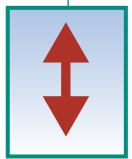

AB-4300-2R shown with extra rack up (left) and extra rack down (right).

Cutter Capacity	Twist Drill / Countersink	Stroke (length)	Speed Range (RPM)
 ø 2 1/16"	 5/8"	 Up to 10 1/4"	 400

Model AB-4300-2 / AB-4300-2R Specifications

Motor Power (Pneumatic)	1.6 HP
Air Consumption @ 90 PSI	64 CFM (1/2" NPT Air Connection)
Hole Capacity	2 1/16" dia.
No Load Speed	400 RPM
Magnet Base Size	8 3/4" L x 3 1/2" W
Dimensions	13 1/2" H x 12 1/2" L x 4 3/4" W
Magnetic Force (1" plate)	1600 lbs.
Arbor Bore	3/4" Weldon Shank
Automatic Lubrication	Included
Stroke Length 4 7/8"	Order Model AB-4300-2
Stroke Length 10 1/4"	Order Model AB-4300-2R

Model Comparison

AB-4300-2R		AB-4300-2	
Drill Stroke			
w/cutters	w/chuck	w/cutters	w/chuck
10 1/4"	7 1/2"	4 7/8"	1 3/4"
Height			
closed	open	closed	open
13 1/2"	22"	13 1/2"	17 1/2"
Weight			
43 lbs.	20 kg	38 lbs.	18 kg

➤ Annular Cutters: pages 54-64 ➤ Accessories: pages 65-71

HB 4400 for Subsea Drilling

Hydraulic for marine and construction – works underwater



Safe • Reliable

- Ideal for industrial, construction, marine and mining applications
- Drill structural steel and other metals
- Hydraulic motor safe for underwater use
- Manually operated permanent magnet with ratchet control has holding strength of 1300 lbs.





Drill up to 2-1/16" dia.

- Uses annular cutters up to 2-1/16" dia.
- Twist drilling capacity up to 1/2" dia.
- Automatic lubrication



With a 3/4" chuck (Part No. 602045A), this model easily converts to a standard drill press with a 3" stroke.

Model HB 4400
Hoses not included

Cutter Capacity	Twist Drill	Stroke (length)	Speed Range (RPM)
			
Ø 2 1/16"	1/2"	Up to 3 3/4"	0-630



Model HB 4400 Specifications

Motor Power (Hydraulic)	1.5 HP
Weight	48 1/2 lbs.
Hole Capacity	2 1/16" dia.
Twist Drill Capacity	1/2" dia.
No Load Speed, Variable	0-630 RPM
Hydraulic Supply	Flow 6.5 GPM @ 2000 PSI
Magnet Base Size	7 1/4" L x 3" W
Dimensions	18 1/2" H x 12 1/2" L x 7" W
Magnetic Force (1" plate)	1300 lbs.
Automatic Lubrication	Included



➤ *Annular Cutters: pages 54-64* ➤ *Accessories: pages 65-71*



Cutter capacity
4" dia.

Model 2 1345 0010 – Hydraulic

Ideal for use in Ex Zones and subsea applications

ATEX Certified

Safe • Reliable

- Hydraulic motor safe for underwater use
- Ideal for industrial, construction, marine and mining applications
- ATEX Certified EX II 2Gc IIB T5
- Drill structural steel and other metals
- Manually operated permanent magnet with lever control has holding strength of 1874 lbs.

Drill up to 4" dia.

- Uses annular cutters up to 4" dia.
- Twist drilling capacity up to 1-1/4" dia.
- Tapping capacity up to 1" dia.



Model 2 1345 0010 Specifications







Motor Power (Hydraulic)	3.4 HP
Weight	50 lbs.
Hole Capacity	4" dia.
Twist Drill Capacity	1 1/4" dia.
No Load Speed, Variable	40-250 RPM
Hydraulic Supply	Flow 5.3 GPM @ 2000 PSI
Magnet Base Size	11 ^{11/16} " L x 4" W
Dimensions	21 ^{1/2} " H x 15 ^{7/16} " L x 7 ^{3/4} " W
Magnetic Force (3/8" plate)	1874 lbs.
Spindle	MT3
Larger Magnet	Order Model 2 1345 0020 12.835" x 7.480" magnet 3,307 lbs. magnetic force

Pipe Clamp – Model 2 1330 8500

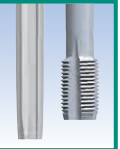

Optional clamp allows right angle drilling of steel, cast iron, cement and plastic pipes up to 19-1/2" dia.

Extension chains available for pipes up to 43-1/4" dia.
P/N 5 1201 9030* – For pipes up to 31-1/2" (800mm)
P/N 5 1201 9020* – For pipes up to 43-1/4" (1100mm)
* 2 pieces needed for one clamp

Cutter Capacity	Twist Drill / Countersink	Ream / Tap	Stroke (length)	Variable Speed (RPM)	Reversible (CW/CCW)
					
ø 4"	ø 1/4" / ø 2"	ø 1/8" / ø 1"	12"	40-250	

Standard Equipment includes hydraulic hose set, coolant bottle, arbor adapter to 3/4" Weldon, arbor adapter to 1-1/4" Weldon, safety chain, drift key, allen keys and carrying case.

➤ Annular Cutters: pages 54-64 ➤ Accessories: pages 65-71

Underwater Tools

Hydraulic- and air-powered tools for use in subsea applications

Grinders - Hydraulic

- 1 1580 0060 N Underwater Hydraulic Horizontal Grinder, 1.3HP, 7000 RPM, Twist throttle, straight grinding wheels
- 1 1585 0010 Underwater Hydraulic Angle Grinder, 1.3HP, 5500 RPM, Lever throttle, grinding wheels up to 7"
- 1 5080 0020 Underwater Hydraulic Peanut Die Grinder, 1.0 HP, 11,500 RPM, Lever throttle, 1/4" collet
- 1 2060 0010 Underwater Hydraulic Vertical Grinder, 4.75 HP, 3600 RPM, grinding wheels up to 9"

Rotary Hammer Drills - Hydraulic and Pneumatic

- 2 2404 0030 Underwater Air Rotary Hammer Drill, SDS Plus, 1" cap. in concrete, 0-3000 BPM, .5 HP, 90 PSI / 21 CFM
- 2 2417 0010 Underwater Air Rotary Hammer Drill, SDS Max, 2" cap. in concrete, 0-2500 BPM, 1.2 HP, 90 PSI / 21 CFM
- 2 2426 0010 Underwater Hydraulic Rotary Hammer Drill, SDS Plus, 1" cap. in concrete, 0-3400 BPM, .8 HP; includes built-in pressure reducing valve
- 2 2418 0020 Underwater Hydraulic Rotary Hammer Drill, SDS Max, 2" cap. in concrete, 2500 BPM, 1.75 HP, includes pressure reducing valve

Core Drills - Hydraulic and Pneumatic

- 2 1317 0030 Underwater Hydraulic Core Drill, 3" max. dia., 3.6 HP, 380/900/1800 RPM
- 2 1335 0010 Underwater Pneumatic Core Drill, 3" max. dia., 3.8 HP, 300/700/1350 RPM

Impact Wrenches - Hydraulic and Pneumatic

- 6 1316 0070 3/4" Air Impact Wrench, 1-1/8" (M 30) max. bolt size, 995 ft-lbs. torque
- 6 1316 0060 1" Air Impact Wrench, 1-1/8" (M 30) max. bolt size, 995 ft-lbs. torque
- 6 1515 0010 3/4" Hydraulic Impact Wrench, 1" (M 27) max. bolt size, 1220 ft-lbs. torque
- 6 1520 0010 1" Hydraulic Impact Wrench, 1-3/8" (M 36) max. bolt size, 1840 ft-lbs. torque



Caution: User must follow all appropriate safety regulations when choosing a tool for their particular working environment.

Other Underwater Tools Available:

Woodboring Drills - Pneumatic See page 79

Reciprocating Saws - Hydraulic and Air See page 120-121

Hacksaws - Hydraulic See page 124-125

Chain Saws - Air and Hydraulic

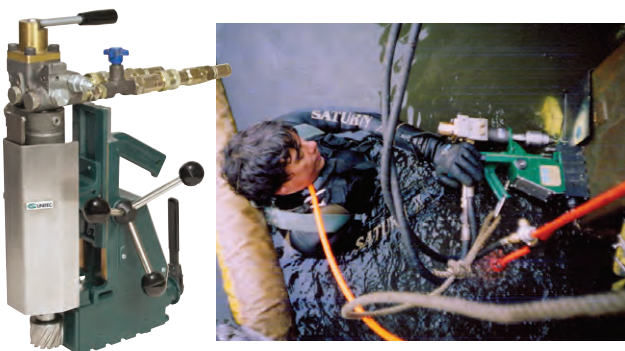

Annular Cutters

Achieve burr-free finished holes, without predrilling or stepdrilling

ANNULAR CUTTERS

Precision-ground flutes provide efficient chip clearance, increasing drilling productivity and decreasing cutter breakage

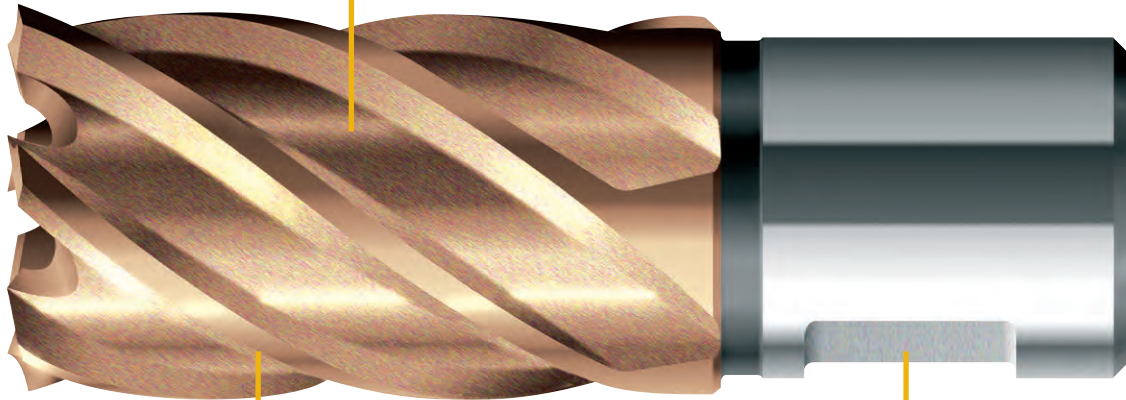

Hardened, high-speed tool steel

Weldon Shank

Benefits of CS Unitec's Cutter Design:

Double-action tooth geometry cuts, splits and ejects chips more efficiently,

- increasing cutting speed
- reducing tooth load
- minimizing tool wear
- lengthening cutter life

Engineered with a tapered inner wall for smooth, easy slug ejection.

Center hole for pilot pin accurately aligns the cutter, allows for internal lubrication and removes the slug.



Perfect drilling to close tolerances without runout.
The result: a burr-free finished hole.



Pilot Pins: How they work...



Pilot Pin included with every annular cutter up to 4" DOC

1: Centering

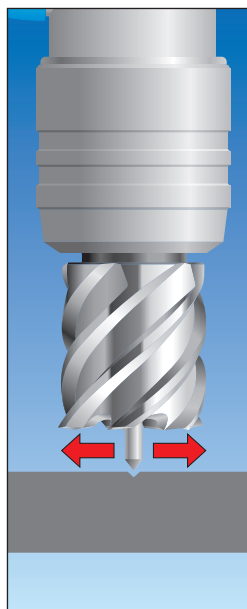

The pilot pin accurately centers cutter over area to be drilled.

2: Oiling

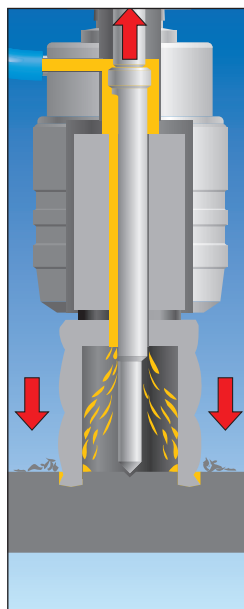

During drilling, the pilot pin retracts and allows internal coolant to reach the cutting teeth.

3: Ejecting

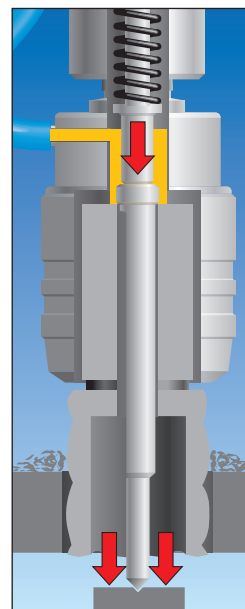

When hole is complete, the slug is automatically ejected from the cutter.

6-Series HSS Unibroach™ Annular Cutters – Pages 56-57

Fully ground HSS annular cutters

Cutting depth:	1"	2"	3"	4"	6"	8"	
Drilling ø:	7/16" - 5-1/8"	7/16" - 5-1/8"	3/4" - 5-1/8"	3/4" - 6"	3/4" - 6"	3/4" - 6"	

8-Series ARMOR-PLATED Unibroach™ Annular Cutters – Pages 58-59

Fully ground HSS annular cutters with TiAlN hard coating

Cutting depth:	1"	2"	3"	
Drilling ø:	7/16" - 5-1/8"	7/16" - 5-1/8"	3/4" - 5-1/8"	

9-Series Unibroach™ TCT Hornet Annular Cutters – Pages 60-61

Sintered carbide annular cutters with Tungsten Carbide tips

Cutting depth:	1"*	2-3/8"	3-3/8"	4"	6"	8"	
Drilling ø:	1/2" - 2"	1/2" - 5-1/8"	3/4" - 5-1/8"	3/4" - 6"	3/4" - 6"	3/4" - 6"	

* 1-3/8" depth for diameters larger than 1-1/2"

For Cobalt Cutters, Rail Cutters and special sizes, see page 63. For One-Touch TCT Cutters, see page 62.



➤ See pages 65-71 for Drill Accessories

Unibroach® Annular Cutters

High-speed steel for drilling 3x faster than twist drills



**Annular Cutter
Recommended
Revolutions Per Minute**
Recommended Feed Rate:
.002 - .004 inches per revolution

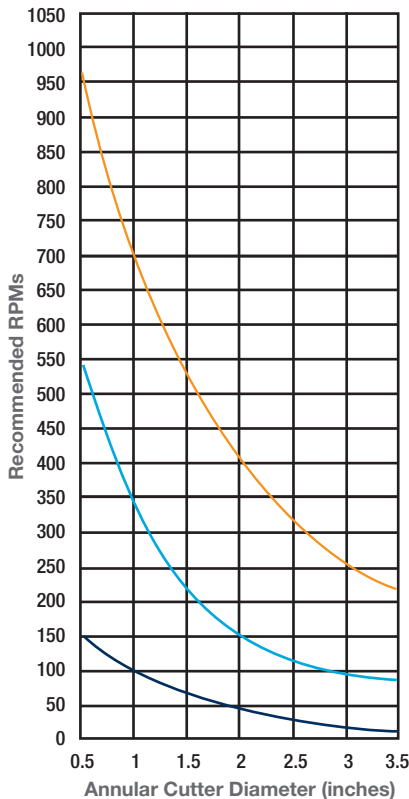

Annular Cutters are the standard hole-making drills in the industry. Ideal for heavy-duty use on-site or in the shop, our HSS Unibroach™ cutters are available in the following sizes:

Drill Depth	1"	2"	3"	4"	6"	8"
Diameter	Ø 7/16" to Ø 5 1/8"	Ø 7/16" to Ø 5 1/8"	Ø 3/4" to Ø 5 1/8"	Ø 3/4" to Ø 6"	Ø 3/4" to Ø 6"	Ø 3/4" to Ø 6"

Special sizes available; metric cutters available on request.
Every annular cutter up to 4" DOC includes a pilot pin.*

- CNC precision ground for fast penetration, accuracy and long life
- Flutes run the length of the cutter for efficient chip clearance, increased drilling productivity and decreased cutter breakage
- Drill holes 3 times faster than twist drills
- Produce reamed-quality, burr-free holes and solid slugs
- Reduce machine size and weight
- Cutting edges are resharpenable
- Eliminate time-consuming, costly pilot holes and step drilling

HSS Cutters must be used with lubricant.
See page 66 for CS Unitec lubricants and cutting oil.



See page 65 for HSS
Annular Cutter Starter Kit.



* Pilot pins supplied with annular cutters up to 4" DOC.
Other pilot pins can be purchased separately.

Unibroach® Stack Cutters are available in diameters from 9/16" to 1 1/8" in 1", 2" and 3" depths. Drill multiple layers of steel without stopping to remove the center slug. Please contact us or consult our price list for more information.

6-Series HSS

1" Depth

Order No.	Diameter
6-1-114	7/16"
6-1-116	1/2"
6-1-118	9/16"
6-1-120	5/8"
6-1-122	11/16"
6-1-124	3/4"
6-1-126	13/16"
6-1-128	7/8"
6-1-130	15/16"
6-1-132	1"
6-1-134	1-1/16"
6-1-136	1-1/8"
6-1-138	1-3/16"
6-1-140	1-1/4"
6-1-142	1-5/16"
6-1-144	1-3/8"
6-1-146	1-7/16"
6-1-148	1-1/2"
6-1-150	1-9/16"
6-1-152	1-5/8"
6-1-154	1-11/16"
6-1-156	1-3/4"
6-1-158	1-13/16"
6-1-160	1-7/8"
6-1-162	1-15/16"
6-1-164	2"
6-1-166	2-1/16"
6-1-168	2-1/8"
6-1-170	2-3/16"
6-1-172	2-1/4"
6-1-174	2-5/16"
6-1-176	2-3/8"
6-1-178	2-7/16"
6-1-180	2-1/2"
6-1-182	2-9/16"
6-1-184	2-5/8"
6-1-186	2-11/16"
6-1-188	2-3/4"
6-1-190	2-13/16"
6-1-192	2-7/8"
6-1-194	2-15/16"
6-1-196	3"
6-1-198	3-1/16"
6-1-1100	3-1/8"
6-1-1102	3-3/16"
6-1-1104	3-1/4"
6-1-1106	3-5/16"
6-1-1108	3-3/8"
6-1-1110	3-7/16"
6-1-1112	3-1/2"
6-1-1114	3-9/16"
6-1-1116	3-5/8"
6-1-1118	3-11/16"
6-1-1120	3-3/4"
6-1-1122	3-13/16"
6-1-1124	3-7/8"
6-1-1126	3-15/16"
6-1-1128	4"

2" Depth

Order No.	Diameter
6-1-214	7/16"
6-1-216	1/2"
6-1-218	9/16"
6-1-220	5/8"
6-1-222	11/16"
6-1-224	3/4"
6-1-226	13/16"
6-1-228	7/8"
6-1-230	15/16"
6-1-232	1"
6-1-234	1-1/16"
6-1-236	1-1/8"
6-1-238	1-3/16"
6-1-240	1-1/4"
6-1-242	1-5/16"
6-1-244	1-3/8"
6-1-246	1-7/16"
6-1-248	1-1/2"
6-1-250	1-9/16"
6-1-252	1-5/8"
6-1-254	1-11/16"
6-1-256	1-3/4"
6-1-258	1-13/16"
6-1-260	1-7/8"
6-1-262	1-15/16"
6-1-264	2"
6-1-266	2-1/16"
6-1-268	2-1/8"
6-1-270	2-3/16"
6-1-272	2-1/4"
6-1-274	2-5/16"
6-1-276	2-3/8"
6-1-278	2-7/16"
6-1-280	2-1/2"
6-1-282	2-9/16"
6-1-284	2-5/8"
6-1-286	2-11/16"
6-1-288	2-3/4"
6-1-290	2-13/16"
6-1-292	2-7/8"
6-1-294	2-15/16"
6-1-296	3"
6-1-298	3-1/16"
6-1-2100	3-1/8"
6-1-2102	3-3/16"
6-1-2104	3-1/4"
6-1-2106	3-5/16"
6-1-2108	3-3/8"
6-1-2110	3-7/16"
6-1-2112	3-1/2"
6-1-2114	3-9/16"
6-1-2116	3-5/8"
6-1-2118	3-11/16"
6-1-2120	3-3/4"
6-1-2122	3-13/16"
6-1-2124	3-7/8"
6-1-2126	3-15/16"
6-1-2128	4"

3" Depth*

Order No.	Diameter
N/A	
N/A	
N/A	
N/A	
6-1-322	11/16"
6-1-324	3/4"
6-1-326	13/16"
6-1-328	7/8"
6-1-330	15/16"
6-1-332	1"
6-1-334	1-1/16"
6-1-336	1-1/8"
6-1-338	1-3/16"
6-1-340	1-1/4"
6-1-342	1-5/16"
6-1-344	1-3/8"
6-1-346	1-7/16"
6-1-348	1-1/2"
6-1-350	1-9/16"
6-1-352	1-5/8"
6-1-354	1-11/16"
6-1-356	1-3/4"
6-1-358	1-13/16"
6-1-360	1-7/8"
6-1-362	1-15/16"
6-1-364	2"
6-1-366	2-1/16"
6-1-368	2-1/8"
6-1-370	2-3/16"
6-1-372	2-1/4"
6-1-374	2-5/16"
6-1-376	2-3/8"
6-1-378	2-7/16"
6-1-380	2-1/2"
6-1-382	2-9/16"
6-1-384	2-5/8"
6-1-386	2-11/16"
6-1-388	2-3/4"
6-1-390	2-13/16"
6-1-392	2-7/8"
6-1-394	2-15/16"
6-1-396	3"
6-1-398	3-1/16"
6-1-3100	3-1/8"
6-1-3102	3-3/16"
6-1-3104	3-1/4"
6-1-3106	3-5/16"
6-1-3108	3-3/8"
6-1-3110	3-7/16"
6-1-3112	3-1/2"
6-1-3114	3-9/16"
6-1-3116	3-5/8"
6-1-3118	3-11/16"
6-1-3120	3-3/4"
6-1-3122	3-13/16"
6-1-3124	3-7/8"
6-1-3126	3-15/16"
6-1-3128	4"

* Cutters with 3" depth have an 8mm pilot hole.

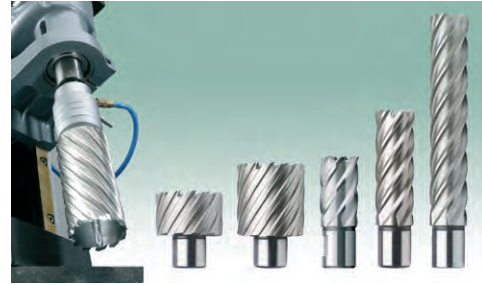

Shank size:

**3/4" for cutters up to 3" dia.
1-1/4" for cutters 3-1/16 to 5-1/8" dia.**

Pilot pin included with every annular cutter up to 4" DOC

Cutter Kits

Each HSS steel cutter kit comes with the following: 9/16", 11/16", 13/16", 15/16", 1-1/16", pilot pins & carrying case.

Order No.	Description
6-1-001	1" depth Cutter Kit
6-1-002	2" depth Cutter Kit

Pilot Pins for 6-Series

Order No.	Description
For 3/4" Shanks	
7-3-102	7/16" - 3" dia., 1" depth
7-3-202	7/16" - 3" dia., 2" depth
7-3-302	3/4" - 3" dia., 3" depth
For 1-1/4" Shanks	
7-3-1002	3-1/16" - 5-1/8" dia., 1" depth
7-3-2002	3-1/16" - 5-1/8" dia., 2" depth
7-3-3002	3-1/16" - 5-1/8" dia., 3" depth

Option for Cutters 3" and 4" Depth

7-3-402	2-piece pin for 3" and 4" depth cutters with 8mm pilot hole.
---------	--

Option for Cutters 6" and 8" Depth

9-3-602 C	Pin for 6" depth cutters with 8mm pilot hole.
9-3-802 C	Pin for 8" depth cutters with 8mm pilot hole.

† We also stock 8" depth HSS cutters and Metric HSS cutters. Larger diameters and special sizes available upon request. Please call us for pricing and delivery.

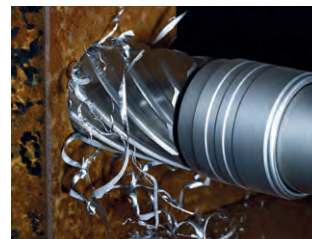

➤ See pages 65-71 for Drill Accessories

Unibroach® Annular Cutters

TiAlN Carbide coating for up to 4x tool life, less friction and more power

Less Friction = Less Heat = More Holes!

ANNULAR CUTTERS



ARMOR-PLATED Unibroach™ Cutters, at 90Rc hardness, are the state-of-the-art in hole cutting technology. They multiply service life, reduce cost and increase productivity.

ARMOR-PLATED Unibroach™ cutters are available in the following sizes:

Drill Depth	1"	2"	3"
Diameter	∅ 7/16" to ∅ 5 1/8"	∅ 7/16" to ∅ 5 1/8"	∅ 3/4" to ∅ 5 1/8"



Special sizes available; metric cutters available on request.

Every annular cutter up to 4" DOC includes a corresponding pilot pin.

- 3 to 4 times longer tool life with TiAlN Carbide coating
- Drill with less friction and more power
- Withstands higher working temperatures – up to 1480°F (800°C)
- Dry drilling or lubricating with water simplifies working conditions and cleanup*
- Prevents cold weld – metal chips do not adhere to the cutter
- Ideal for structural steel and hard metal
- 3/4" dia. shank (1 1/4" dia. shank available)

After the TiAlN Carbide coating is worn, lubricate with cutting oil



**Annular Cutter
Recommended
Revolutions Per Minute**
Recommended Feed Rate:
.002 - .004 inches per revolution

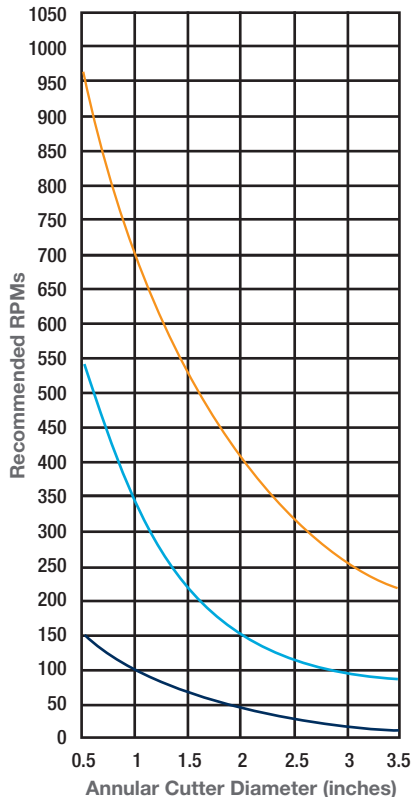

Aluminum
200 ft./min.

**Mild Steel
(Carbon)**
80 ft./min.

**High Tensile
Steel
(Stainless)**
30 ft./min.

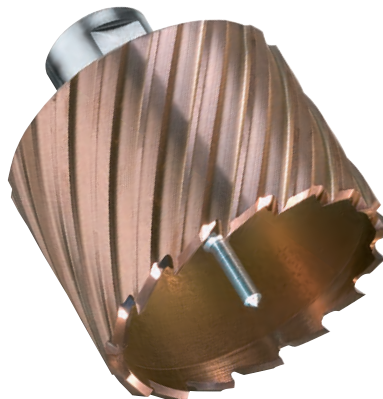

See page 65 for ARMOR-PLATED Unibroach™ TiAlN Carbide-Coated Annular Cutter Starter Kit.

* Pilot pins supplied with annular cutters up to 4" DOC. Other pilot pins can be purchased separately.

8-Series ARMOR-PLATED TiAIN

ARMOR-PLATED = Less Friction = Less Heat = More Holes!
Increase tool life and achieve faster feed rates



Shank size: 3/4" up to 3" dia.

ARMOR-PLATED Unibroach™ Cutters, at 90Rc hardness, are the state-of-the-art in hole cutting technology. They multiply service life, reduce cost and increase productivity.



Pilot pin included with every annular cutter up to 4" DOC

1" Depth	
Order No.	Diameter
8-1-114 T	7/16"
8-1-116 T	1/2"
8-1-118 T	9/16"
8-1-120 T	5/8"
8-1-122 T	11/16"
8-1-124 T	3/4"
8-1-126 T	13/16"
8-1-128 T	7/8"
8-1-130 T	15/16"
8-1-132 T	1"
8-1-134 T	1-1/16"
8-1-136 T	1-1/8"
8-1-138 T	1-3/16"
8-1-140 T	1-1/4"
8-1-142 T	1-5/16"
8-1-144 T	1-3/8"
8-1-146 T	1-7/16"
8-1-148 T	1-1/2"
8-1-150 T	1-9/16"
8-1-152 T	1-5/8"
8-1-154 T	1-11/16"
8-1-156 T	1-3/4"
8-1-158 T	1-13/16"
8-1-160 T	1-7/8"
8-1-162 T	1-15/16"
8-1-164 T	2"
8-1-166 T	2-1/16"

2" Depth	
Order No.	Diameter
8-1-214 T	7/16"
8-1-216 T	1/2"
8-1-218 T	9/16"
8-1-220 T	5/8"
8-1-222 T	11/16"
8-1-224 T	3/4"
8-1-226 T	13/16"
8-1-228 T	7/8"
8-1-230 T	15/16"
8-1-232 T	1"
8-1-234 T	1-1/16"
8-1-236 T	1-1/8"
8-1-238 T	1-3/16"
8-1-240 T	1-1/4"
8-1-242 T	1-5/16"
8-1-244 T	1-3/8"
8-1-246 T	1-7/16"
8-1-248 T	1-1/2"
8-1-250 T	1-9/16"
8-1-252 T	1-5/8"
8-1-254 T	1-11/16"
8-1-256 T	1-3/4"
8-1-258 T	1-13/16"
8-1-260 T	1-7/8"
8-1-262 T	1-15/16"
8-1-264 T	2"
8-1-266 T	2-1/16"

3" Depth*	
Order No.	Diameter
N/A	
N/A	
N/A	
N/A	
N/A	
8-1-324 T	3/4"
8-1-326 T	13/16"
8-1-328 T	7/8"
8-1-330 T	15/16"
8-1-332 T	1"
8-1-334 T	1-1/16"
8-1-336 T	1-1/8"
8-1-338 T	1-3/16"
8-1-340 T	1-1/4"
8-1-342 T	1-5/16"
8-1-344 T	1-3/8"
8-1-346 T	1-7/16"
8-1-348 T	1-1/2"
8-1-350 T	1-9/16"
8-1-352 T	1-5/8"
8-1-354 T	1-11/16"
8-1-356 T	1-3/4"
8-1-358 T	1-13/16"
8-1-360 T	1-7/8"
8-1-362 T	1-15/16"
8-1-364 T	2"
8-1-366 T	2-1/16"

* Cutters with 3" depth have an 8mm dia. pilot hole.

ARMOR-PLATED Cutter Kits

Each armor-plated cutter kit comes with the following: 9/16", 11/16", 13/16", 15/16", 1-1/16", pilot pins & carrying case.

Order No.	Description
8-1-001 T	1" depth Cutter Kit
8-1-002 T	2" depth Cutter Kit

Pilot Pins for 8-Series

Order No.	Description
For 3/4" Shanks	
7-3-102	7/16" - 3" dia., 1" depth
7-3-202	7/16" - 3" dia., 2" depth
7-3-302	3/4" - 3" dia., 3" depth

Option for Cutters 3" and 4" Depth

	
7-3-402	2-piece pin for 3" and 4" depth cutters with 8mm pilot hole.

3"+ Diameter Cutters

Metric and larger diameter cutters available on request.

ARMOR-PLATED Unibroach™ TiAIN Carbide-Coated Cutters:

- Drill with less friction and more power
- Withstand higher working temperatures – up to 1480°F (800°C)
- Dry drill or lubricate with water to simplify working conditions and cleanup**
- Prevent cold weld – metal chips do not adhere to the cutter
- Are ideal for structural steel and hard metal

** After the TiAIN Carbide coating is worn, lubricate with cutting oil

➤ See pages 65-71 for Drill Accessories

Unibroach® Annular Cutters

TCT Carbide Hornet – tungsten carbide-tipped for high-speed cutting

ANNULAR CUTTERS



- Use high-speed RPM for best results and faster holmaking
- Ideal for drilling steel with rust or paint and bolting applications
- Will outlast High-speed Steel cutters
- Leaves a burr-free finished hole
- Available in all sizes (fractional and metric)
- 2 flats
- $\frac{3}{4}$ " or $1\frac{1}{4}$ " shank

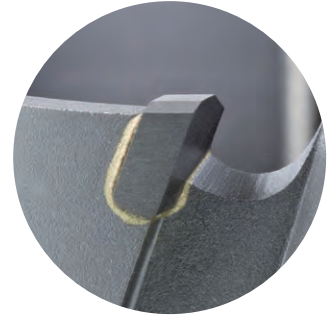

Closeup of tungsten-carbide teeth.

TCT Hornet cutters are available in the following sizes:

Drill Depth	1"	1-3/8"	2-3/8"	3-3/8"	4"	6"	8"
Diameter	$\varnothing \frac{1}{2}$ " to $\varnothing 1\frac{1}{2}$ "	$\varnothing \frac{19}{16}$ " to $\varnothing 2$ "	$\varnothing \frac{1}{2}$ " to $\varnothing 5\frac{1}{8}$ "	$\varnothing \frac{3}{4}$ " to $\varnothing 5\frac{1}{8}$ "	$\varnothing \frac{3}{4}$ " to $\varnothing 6$ "	$\varnothing \frac{13}{16}$ " to $\varnothing 6$ "	$\varnothing \frac{13}{16}$ " to $\varnothing 6$ "

Special sizes available; metric cutters available on request.

*Every annular cutter up to 4" DOC includes a corresponding pilot pin.**



Armor plating available upon request.



* Pilot pins supplied with annular cutters up to 4" DOC. Other pilot pins can be purchased separately.

9-Series Annular Cutter Recommended RPM Rates

Cutter Size	Stainless & Alloy Steel	Mild Steel	Iron Plate
	RPM	RPM	RPM
$\frac{1}{2}$ " - $\frac{5}{8}$ "	500 - 800	600 - 1000	800 - 1200
$\frac{11}{16}$ " - $\frac{13}{16}$ "	400 - 640	480 - 800	640 - 960
$\frac{7}{8}$ " - $\frac{15}{16}$ "	330 - 530	400 - 660	530 - 800
1" - $1\frac{3}{16}$ "	270 - 420	320 - 530	420 - 640
$1\frac{1}{4}$ " - $1\frac{3}{8}$ "	230 - 370	270 - 460	360 - 550
$1\frac{7}{16}$ " - $1\frac{9}{16}$ "	200 - 320	240 - 400	320 - 480
$1\frac{5}{8}$ " - $1\frac{3}{4}$ "	180 - 280	210 - 350	280 - 420
$1\frac{13}{16}$ " - 2"	160 - 260	190 - 320	260 - 380
$2\frac{1}{16}$ " - $2\frac{3}{16}$ "	145 - 230	170 - 290	230 - 350
$2\frac{1}{4}$ " - $2\frac{3}{8}$ "	135 - 210	160 - 270	210 - 320
$2\frac{7}{16}$ " - $2\frac{9}{16}$ "	120 - 200	150 - 250	200 - 300
$2\frac{5}{8}$ " - $2\frac{3}{4}$ "	115 - 180	140 - 230	180 - 270
$2\frac{13}{16}$ " - $2\frac{15}{16}$ "	110 - 170	130 - 210	170 - 260
3" - $3\frac{1}{8}$ "	100 - 160	120 - 200	160 - 240
$3\frac{3}{16}$ " - $3\frac{3}{8}$ "	95 - 150	115 - 190	150 - 230
$3\frac{7}{16}$ " - $3\frac{9}{16}$ "	90 - 140	110 - 180	140 - 210
$3\frac{5}{8}$ " - $3\frac{3}{4}$ "	85 - 135	105 - 170	135 - 200
$3\frac{13}{16}$ " - $3\frac{15}{16}$ "	80 - 130	95 - 160	130 - 195
4" - $4\frac{5}{16}$ "	70 - 120	90 - 145	120 - 170
$4\frac{3}{8}$ " - $4\frac{3}{4}$ "	70 - 110	80 - 135	110 - 160
$4\frac{13}{16}$ " - $5\frac{1}{8}$ "	65 - 100	75 - 125	100 - 150

9-Series - TCT Carbide Hornet

1" Depth

Order No.	Diameter
9-1-116 C	1/2"
9-1-118 C	9/16"
9-1-120 C	5/8"
9-1-122 C	11/16"
9-1-124 C	3/4"
9-1-126 C	13/16"
9-1-128 C	7/8"
9-1-130 C	15/16"
9-1-132 C	1"

1-3/8" Depth

Order No.	Diameter
9-1-134 C	1-1/16"
9-1-136 C	1-1/8"
9-1-138 C	1-3/16"
9-1-140 C	1-1/4"
9-1-142 C	1-5/16"
9-1-144 C	1-3/8"
9-1-146 C	1-7/16"
9-1-148 C	1-1/2"

2-3/8" Depth

Order No.	Diameter
9-1-216 C	1/2"
9-1-218 C	9/16"
9-1-220 C	5/8"
9-1-222 C	11/16"
9-1-224 C	3/4"
9-1-226 C	13/16"
9-1-228 C	7/8"
9-1-230 C	15/16"
9-1-232 C	1"
9-1-234 C	1-1/16"
9-1-236 C	1-1/8"
9-1-238 C	1-3/16"
9-1-240 C	1-1/4"
9-1-242 C	1-5/16"
9-1-244 C	1-3/8"
9-1-246 C	1-7/16"
9-1-248 C	1-1/2"
9-1-250 C	1-9/16"
9-1-252 C	1-5/8"
9-1-254 C	1-11/16"
9-1-256 C	1-3/4"
9-1-258 C	1-13/16"
9-1-260 C	1-7/8"
9-1-262 C	1-15/16"
9-1-264 C	2"

Order No.	Diameter
9-1-266 C	2-1/16"
9-1-268 C	2-1/8"
9-1-270 C	2-3/16"
9-1-272 C	2-1/4"
9-1-274 C	2-5/16"
9-1-276 C	2-3/8"
9-1-278 C	2-7/16"
9-1-280 C	2-1/2"
9-1-282 C	2-9/16"
9-1-284 C	2-5/8"
9-1-286 C	2-11/16"
9-1-288 C	2-3/4"
9-1-290 C	2-13/16"
9-1-292 C	2-7/8"
9-1-294 C	2-15/16"
9-1-296 C	3"
9-1-298 C	3-1/16"
9-1-2100 C	3-1/8"
9-1-2102 C	3-3/16"
9-1-2104 C	3-1/4"
9-1-2106 C	3-5/16"
9-1-2108 C	3-3/8"
9-1-2110 C	3-7/16"
9-1-2112 C	3-1/2"

3-3/8" Depth

Order No.	Diameter
9-1-322 C	11/16"
9-1-324 C	3/4"
9-1-326 C	13/16"
9-1-328 C	7/8"
9-1-330 C	15/16"
9-1-332 C	1"
9-1-334 C	1-1/16"
9-1-336 C	1-1/8"
9-1-338 C	1-3/16"
9-1-340 C	1-1/4"
9-1-342 C	1-5/16"
9-1-344 C	1-3/8"
9-1-346 C	1-7/16"
9-1-348 C	1-1/2"
9-1-350 C	1-9/16"
9-1-352 C	1-5/8"
9-1-354 C	1-11/16"
9-1-356 C	1-3/4"
9-1-358 C	1-13/16"
9-1-360 C	1-7/8"
9-1-362 C	1-15/16"
9-1-364 C	2"
9-1-366 C	2-1/16"

Order No.	Diameter
9-1-368 C	2-1/8"
9-1-370 C	2-3/16"
9-1-372 C	2-1/4"
9-1-374 C	2-5/16"
9-1-376 C	2-3/8"
9-1-378 C	2-7/16"
9-1-380 C	2-1/2"
9-1-382 C	2-9/16"
9-1-384 C	2-5/8"
9-1-386 C	2-11/16"
9-1-388 C	2-3/4"
9-1-390 C	2-13/16"
9-1-392 C	2-7/8"
9-1-394 C	2-15/16"
9-1-396 C	3"
9-1-398 C	3-1/16"
9-1-3100 C	3-1/8"
9-1-3102 C	3-3/16"
9-1-3104 C	3-1/4"
9-1-3106 C	3-5/16"
9-1-3108 C	3-3/8"
9-1-3110 C	3-7/16"
9-1-3112 C	3-1/2"
9-1-3114 C	3-9/16"

Order No.	Diameter
9-1-2114 C	3-9/16"
9-1-2116 C	3-5/8"
9-1-2118 C	3-11/16"
9-1-2120 C	3-3/4"
9-1-2122 C	3-13/16"
9-1-2124 C	3-7/8"
9-1-2126 C	3-15/16"
9-1-2128 C	4"
9-1-2130 C	4-1/16"
9-1-2132 C	4-1/8"
9-1-2134 C	4-3/16"
9-1-2136 C	4-1/4"
9-1-2138 C	4-5/16"
9-1-2140 C	4-3/8"
9-1-2142 C	4-7/16"
9-1-2144 C	4-1/2"
9-1-2146 C	4-9/16"
9-1-2148 C	4-5/8"
9-1-2150 C	4-11/16"
9-1-2152 C	4-3/4"
9-1-2154 C	4-13/16"
9-1-2156 C	4-7/8"
9-1-2158 C	4-15/16"
9-1-2160 C	5"
9-1-2162 C	5-1/8"

Order No.	Diameter
9-1-3116 C	3-5/8"
9-1-3118 C	3-11/16"
9-1-3120 C	3-3/4"
9-1-3122 C	3-13/16"
9-1-3124 C	3-7/8"
9-1-3126 C	3-15/16"
9-1-3128 C	4"
9-1-3130 C	4-1/16"
9-1-3132 C	4-1/8"
9-1-3134 C	4-3/16"
9-1-3136 C	4-1/4"
9-1-3138 C	4-5/16"
9-1-3140 C	4-3/8"
9-1-3142 C	4-7/16"
9-1-3144 C	4-1/2"
9-1-3146 C	4-9/16"
9-1-3148 C	4-5/8"
9-1-3150 C	4-11/16"
9-1-3152 C	4-3/4"
9-1-3154 C	4-13/16"
9-1-3156 C	4-7/8"
9-1-3158 C	4-15/16"
9-1-3160 C	5"
9-1-3162 C	5-1/8"



Shank size:

3/4" for cutters up to 3" dia.
1-1/4" for cutters 3-1/16 to 5-1/8" dia.

Pilot pin included with every annular cutter up to 4" DOC

Cutter Kits

Each hornet carbide cutter kit comes with the following: 9/16", 11/16", 13/16", 15/16", 1-1/16", pilot pins & carrying case.

Order No.	Description
9-1-001 C	1" depth Cutter Kit
9-1-002 C	2-3/8" depth Cutter Kit

****We also stock Metric Carbide cutters. Please call us for pricing and delivery. Larger diameters and special sizes are available upon request.**

Pilot Pins for 9-Series

Order No.	Description
For 3/4" Shanks	
9-3-101 C	1/2" - 1-1/2" dia., 1" depth
9-3-102 C	1-9/16" - 2" dia., 1-3/8" depth
9-3-202 C	1/2" - 3" dia., 2-3/8" depth
9-3-302 C	3/4" - 3" dia., 3-3/8" depth
For 1-1/4" Shanks	
9-3-202A C	3-1/16" - 5-1/8" dia., 2-3/8" depth
9-3-302A C	3-1/16" - 5-1/8" dia., 3-3/8" depth

Option for Cutters 3-3/8" and 4" Depth

Order No.	Description
7-3-402	2-piece pin for 3-3/8" and 4" depth cutters with 8mm pilot hole.

Option for Cutters 6" and 8" Depth

9-3-602 C	Pin for 6" depth cutters with 8mm pilot hole.
9-3-802 C	Pin for 8" depth cutters with 8mm pilot hole.



➤ See pages 65-71 for Drill Accessories

10-Series One-Touch TCT

Tungsten carbide-tipped with one-touch shank



- No-tool cutter replacement
- When holding with a set screw, tighten to weld on flat rather than dimple area
- Leaves a burr-free finished hole
- 3/4" shank
- Compatible with Nitto Kohki and other auto-feed machines
- Armor plating also available upon request



One-Touch TCT cutters are available in the following sizes:

- 1-3/8" drill depth – \varnothing 1/2" to \varnothing 2"
- 2-3/8" drill depth – \varnothing 1/2" to \varnothing 2³/₄"
- 3-3/8" drill depth – \varnothing 1¹/₁₆" to \varnothing 1¹/₁₆"

Every 10-Series annular cutter includes a corresponding pilot pin.

- Metric cutters available on request

1-3/8" Depth	
Order No.	Diameter
10-1-116 C	1/2"
10-1-118 C	9/16"
10-1-120 C	5/8"
10-1-122 C	11/16"
10-1-124 C	3/4"
10-1-126 C	13/16"
10-1-128 C	7/8"
10-1-130 C	15/16"
10-1-132 C	1"
10-1-134 C	1-1/16"
10-1-136 C	1-1/8"
10-1-138 C	1-3/16"
10-1-140 C	1-1/4"
10-1-142 C	1-5/16"
10-1-144 C	1-3/8"
10-1-146 C	1-7/16"
10-1-148 C	1-1/2"
10-1-150 C	1-9/16"
10-1-152 C	1-5/8"
10-1-154 C	1-11/16"
10-1-156 C	1-3/4"
10-1-158 C	1-13/16"
10-1-160 C	1-7/8"
10-1-162 C	1-15/16"
10-1-164 C	2"

2-3/8" Depth	
Order No.	Diameter
10-1-216 C	1/2"
10-1-218 C	9/16"
10-1-220 C	5/8"
10-1-222 C	11/16"
10-1-224 C	3/4"
10-1-226 C	13/16"
10-1-228 C	7/8"
10-1-230 C	15/16"
10-1-232 C	1"
10-1-234 C	1-1/16"
10-1-236 C	1-1/8"
10-1-238 C	1-3/16"
10-1-240 C	1-1/4"
10-1-242 C	1-5/16"
10-1-244 C	1-3/8"
10-1-246 C	1-7/16"
10-1-248 C	1-1/2"
10-1-250 C	1-9/16"
10-1-252 C	1-5/8"
10-1-254 C	1-11/16"
10-1-256 C	1-3/4"
10-1-258 C	1-13/16"
10-1-260 C	1-7/8"
10-1-262 C	1-15/16"
10-1-264 C	2"

3-3/8" Depth	
Order No.	Diameter
10-1-266 C	2-1/16"
10-1-268 C	2-1/8"
10-1-270 C	2-3/16"
10-1-272 C	2-1/4"
10-1-274 C	2-5/16"
10-1-276 C	2-3/8"
10-1-278 C	2-7/16"
10-1-280 C	2-1/2"
10-1-282 C	2-5/8"
10-1-288 C	2-3/4"

Pilot pin included with every 10-Series annular cutter



Shank size: 3/4"

Pilot Pins for 10-Series

Order No.	Description
For 3/4" Shanks	
9-3-102 C	9/16" - 2" dia., 1-3/8" depth
9-3-202 C	1/2" - 2-3/4" dia., 2-3/8" depth
9-3-302 C	11/16" - 1-1/16" dia., 3-3/8" depth

➤ See pages 65-71 for Drill Accessories

Rail Cutters

Cut holes up to 1-11/16" dia. in track rail

- Round, clean, burr-free hole – better than spade drills
- 3/4" shank
- More cutting teeth to distribute the load evenly – increase tool life and achieve faster feed rates
- Pilot pin included with each 4-Series cutter
- Armor plating available upon request



4-Series Carbide-Tipped Rail Cutters

- Carbide-tipped rail bits for long life and quick, efficient cutting through rust and corrosion

1-3/8" Depth

Order No.	Diameter	Order No.	Diameter
4-1-124 C	3/4"	4-1-140 C	1-1/4"
4-1-128 C	7/8"	4-1-142 C	1-5/16"
4-1-130 C	15/16"	4-1-144 C	1-3/8"
4-1-132 C	1"	4-1-146 C	1-7/16"
4-1-134 C	1-1/16"	4-1-148 C	1-1/2"
4-1-136 C	1-1/8"	4-1-152 C	1-5/8"
4-1-138 C	1-3/16"	4-1-154 C	1-11/16"



Pilot Pin for 4-Series

Order No.	Description
For 3/4" Shanks	
4-3-102	3/4" - 1-11/16" dia., 1-3/8" depth

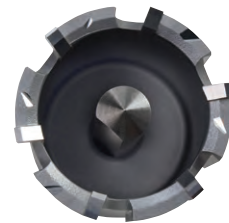

47-Series Lightning Rail Cutters

- Cobalt rail bits for increased wear resistance
- Thick cutter wall for extra durability and extended tool life
- Turn-style mounting allows quick and easy installation without tools.

1-1/4" Depth

Order No.	Diameter	Order No.	Diameter
47-1-124 C	3/4"	47-1-140 C	1-1/4"
47-1-128 C	7/8"	47-1-142 C	1-5/16"
47-1-130 C	15/16"	47-1-144 C	1-3/8"
47-1-132 C	1"	47-1-146 C	1-7/16"
47-1-134 C	1-1/16"	47-1-148 C	1-1/2"
47-1-136 C	1-1/8"	47-1-152 C	1-5/8"
47-1-138 C	1-3/16"	47-1-154 C	1-11/16"

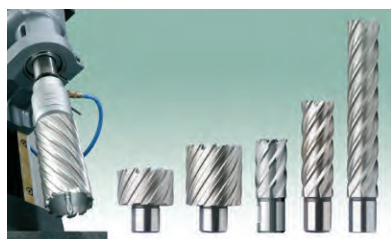

Unibroach® Cobalt Cutters

- 5% cobalt for increased wear resistance
- Excellent results when drilling high-tensile steel and difficult-to-machine materials
- Available with TiAlN coating upon request
- Available for hole sizes up to 5" dia.
- 3/4" shank is standard for cutters up to 3" dia.
- Metric cutters available on request
- See our price list for part numbers

➤ See pages 65-71 for Drill Accessories

Carbide-Tipped Hole Saws

CARBIDE-TIPPED HOLE SAWS



Cut holes in steel plate up to 3/8" thick



Model EHB 16/2.4
S R/L C: 2-speed,
variable-speed drill
with safety clutch

- Tungsten carbide-tipped cutting edges last longer and can be run at higher feeds and speeds to create holes of exceptional quality and accuracy
- One-piece construction; diameters from 9/16" to 4 1/2"

Designed for use with hand-held drills – recommended drills include our EHB 16 series or other hand-held drills with slip clutch – see page 72



1-Series Carbide-Tipped Hole Cutters

1" effective length
Center twist pilot drill
Safety Collar Stop

3/8" shank on cutters up to 3-1/4" dia.
1/2" shank on cutters 3-5/16" dia. and larger

2-Series Carbide-Tipped Hole Cutters Extra Heavy Duty

5/8" effective length
Spring-loaded Pilot Pin

Cutters feature milled, 3-flat shank designed to fit 1/2" chucks.



Order No.	Diameter
1-1-118*	9/16"
1-1-120*	5/8"
1-1-122	11/16"
1-1-124	3/4"
1-1-126	13/16"
1-1-128	7/8"
1-1-130	15/16"
1-1-132	1"
1-1-134	1-1/16"
1-1-136	1-1/8"
1-1-138	1-3/16"
1-1-140	1-1/4"
1-1-142	1-5/16"
1-1-144	1-3/8"
1-1-146	1-7/16"
1-1-148	1-1/2"
1-1-150	1-9/16"
1-1-152	1-5/8"
1-1-154	1-11/16"
1-1-156	1-3/4"
1-1-158	1-13/16"
1-1-160	1-7/8"
1-1-162	1-15/16"
1-1-164	2"

Order No.	Diameter
1-1-166	2-1/16"
1-1-168	2-1/8"
1-1-170	2-3/16"
1-1-172	2-1/4"
1-1-174	2-5/16"
1-1-176	2-3/8"
1-1-178	2-7/16"
1-1-180	2-1/2"
1-1-182	2-9/16"
1-1-184	2-5/8"
1-1-186	2-11/16"
1-1-188	2-3/4"
1-1-190	2-13/16"
1-1-192	2-7/8"
1-1-194	2-15/16"
1-1-196	3"
1-1-198	3-1/16"
1-1-1100	3-1/8"
1-1-1102	3-3/16"
1-1-1104	3-1/4"
1-1-1106	3-5/16"
1-1-1108	3-3/8"
1-1-1110	3-7/16"
1-1-1112	3-1/2"

Order No.	Diameter
1-1-1114	3-9/16"
1-1-1116	3-5/8"
1-1-1118	3-11/16"
1-1-1120	3-3/4"
1-1-1122	3-13/16"
1-1-1124	3-7/8"
1-1-1126	3-15/16"
1-1-1128	4"
1-1-1136	4-1/4"
1-1-1144	4-1/2"

1-Series Accessories

Order No.	Description
1-1-drill	Center Pilot Drill
1-1-spring	Spring
1-1-screw	Screw

Order No.	Diameter
2-1-118	9/16"
2-1-120	5/8"
2-1-122	11/16"
2-1-124	3/4"
2-1-126	13/16"
2-1-128	7/8"
2-1-130	15/16"
2-1-132	1"
2-1-134	1-1/16"
2-1-136	1-1/8"
2-1-138	1-3/16"
2-1-140	1-1/4"
2-1-142	1-5/16"
2-1-144	1-3/8"

2-Series Accessories

Order No.	Description
2-1-pilot	Pilot/Ejector Pin
2-1-screw	Screw



* These cutters do not include springs.

Accessories

Starter Kits

CS Unitec starter kits offer the essentials you need to begin drilling. We have three options that provide a cost-effective tool set for your application.



HSS Steel Cutter Starter Kit

ZST 100S Kit Includes:

Set of 5 annular cutters (one each of the following):

- 9/16" dia. x 1" depth (6-1-118)
- 11/16" dia. x 1" depth (6-1-122)
- 13/16" dia. x 1" depth (6-1-126)
- 15/16" dia. x 1" depth (6-1-130)
- 1-1/16" dia. x 1" depth (6-1-134)

2 pilot pins • 1 cutter storage box • 1 Power Worker magnetic stick (POW 100)
1 quart high-performance cutting oil (ZHS 006)

See pages 56-57 for more information on HSS annular cutters.



Armor-Plated TiAlN Carbide-Coated Cutter Starter Kit

ZST 100P Kit Includes:

Set of 5 annular cutters (one each of the following):

- 9/16" dia. x 1" depth (8-1-118)
- 11/16" dia. x 1" depth (8-1-122)
- 13/16" dia. x 1" depth (8-1-126)
- 15/16" dia. x 1" depth (8-1-130)
- 1-1/16" dia. x 1" depth (8-1-134)

2 pilot pins • 1 cutter storage box • 1 Power Worker magnetic stick (POW 100)
1 quart high-performance cutting oil (ZHS 006)

See pages 58-59 for more information on Armor-Plated TiAlN Carbide-Coated annular cutters.

Other annular cutter kits are available – contact CS Unitec for details.



HSS Steel Cutter Starter Kit with Power Cleaner

ZST 200S Kit Includes:

Set of 5 annular cutters (one each of the following):

- 9/16" dia. x 1" depth (6-1-118)
- 11/16" dia. x 1" depth (6-1-122)
- 13/16" dia. x 1" depth (6-1-126)
- 15/16" dia. x 1" depth (6-1-130)
- 1-1/16" dia. x 1" depth (6-1-134)

2 pilot pins • 1 cutter storage box • 1 Power Cleaner (POW 200)
1 quart high-performance cutting oil (ZHS 006)

See pages 56-57 for more information on HSS annular cutters.



See page 70 for more information on the Power Cleaner (POW 200) and Power Worker magnetic stick (POW 100)



Accessories

Coolants and Cutting Pastes

Coolant extends the life of cutting tools – Ideal for cutting steel, stainless steel and hard metals

ProLube™

Your cutting tools will work cooler, longer and more efficiently with ProLube™ Lubricants from CS Unitec.

- Prolong tool life by reducing friction and wear
- Unique composition provides excellent adhesion to cutting tools for maximum lubrication
- Corrosion inhibitor
- Non-toxic



**Water soluble
16:1**

ProLube™

Paste (12 oz. tub) – Part No. **CS 7030-712**

Liquid (1 gallon) – Part No. **CS 7010-504**



- High-performance
- Liquid coolant is concentrated for dilution with water
- Eco-friendly

Paste (tube) – Part No. **ZHS 570**

Paste (12-pack tubes) – Part No. **ZHS 572**

Paste (2.2 lb. tub) – Part No. **ZHS 550**

Liquid (1 quart) – Part No. **ZHB 001**

Upgrade your drill's cooling system: see page 67 for arbors with automatic cooling.

Cutting Oil

- High-performance, biodegradable, non-hazardous oils and pastes
- Oils for heavy removal of metal, including stainless steel
- Chlorine-free (MSDS on bottle/tub)
- Not necessary to dilute with water

Cutting Oil:

Part No. **ZHS 006** (quart)

Part No. **ZHS 005** (gallon)



Pressurized Coolant Bottle

Use with any automatic internal lubrication system.
Part No. **9 4002 0020 N**

Pilot Pins for Cutters

- Milled channel efficiently supplies internal lubrication to cutting teeth
- Available for cutter diameters ranging from 7/16" to 5 1/8" and up to 8" depth of cut
- See price list for part numbers



**Shown at right:
2-piece pin for
3" and 4" depth
cutters with
8mm pilot hole
(Part No. 7-3-402).**

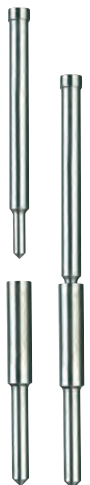

Accessories

Arbors for Annular Cutters

- Use on any magnetic drill stand, drill press or shop equipment with a Morse Taper intake of No. 2, 3 or 4
- Available for Annular Cutter shank sizes of 3/4" or 1 1/4" Weldon
- Available for automatic internal cooling or manual cooling



Manual Cooling

- ZIA 219M** – Morse Taper No. 2
3/4" arbor bore
- ZIA 319M** – Morse Taper No. 3
3/4" arbor bore
- ZIA 30/75** – Morse Taper No. 3
3/4" arbor bore, 3" depth
- ZIA 419M** – Morse Taper No. 4
3/4" arbor bore



Automatic Cooling

- ZIA 219KN** – Morse Taper No. 2
3/4" arbor bore
- ZIA 319KN** – Morse Taper No. 3
3/4" arbor bore
- ZIA 30/32** – Morse Taper No. 3
1 1/4" arbor bore
- ZIA 432 KN** – Morse Taper No. 4
1 1/4" arbor bore

Quick-Lock Arbor with Automatic Internal Cooling

- Keyless for fast, no-tools changeover for 3/4" dia. shank annular cutters
- Automatic internal cooling
- Turn, click... go!

ZSS 200 – Morse Taper No. 2
for 3/4" dia. shank
annular cutters

ZSS 300 – Morse Taper No. 3
for 3/4" dia. shank
annular cutters



**turn,
click...**



**Keyless,
quick-change
system for annular
cutters saves time
and money.**

Just twist and lock!



Drill Chucks for Straight-Shank Twist Drills

- Two capacities: 1/2" and 3/4"; four chucks and adapters to fit all magnetic drills

- A) **IBC 17** – 1/2" chuck for CSU 32 series
- B) **IBC 18** – 1/2" chuck with 3/4" shank for MABasic 200, MABasic 400 and AIRBOR™ (fits all drills with 3/4" arbor bore)
- C) **IBC 21** – 3/4" chuck with MT3 shank for MAB 525, MAB 825, MAB 845 and CSU 100/3RL
- D) **IBC 22** – 3/4" chuck with MT2 shank for MABasic 450, MAB 455, MAB 485 and CSU 50 series



Accessories

Extensions for Annular Cutters

Extra-long holders extend stroke of drills



- Extend cutter reach up to 18"
- Available for magnetic drills with 3/4" arbor bore or MT3
- Also available with 3 flats for straight shank drill chucks and R8 shanks for drill presses
- Drill difficult-to-reach areas
- Extend cutter reach over the side or through an existing hole*

7-9-902 – 2" extension
7-9-903 – 3" extension
7-9-906 – 6" extension
7-9-912 – 12" extension
7-9-918 – 18" extension

7-9-1146 – 6" extension,
 1-1/4" male x 1-1/4"
 female shank

* Hole diameter must be larger than 1 5/16"
 to accommodate width of extension



We also offer extensions with the following connections:

**3 Flats for Geared
 Chucks x
 3/4" arbor**



7-9-100 – 2-1/8" length, 1/2" shank
7-9-200 – 2" length, 3/4" shank

R8



7-9-500 – R8, 1-3/4" length; 3/4" arbor bore
7-9-506 – R8, 6" length; 3/4" arbor bore
7-9-700 – R8, 2-3/4" length; 1-1/4" arbor bore

2-in-1 Drill/Taps Drill and tap with one tool

National Coarse Threads (UNC) – sizes available:

CS500 – 1/2" x 13 UNC
CS625 – 5/8" x 11 UNC
CS750 – 3/4" x 10 UNC

CS875 – 7/8" x 9 UNC
CS1000 – 1" x 8 UNC
CSDT-UNCKIT – 1/2", 5/8", 3/4" & 1" drill/taps



82° and 90° Countersinks

- Manufactured of HSS with 5% cobalt
- 3/4" Weldon shank

Countersink hole sizes:

CTS 30 from 5/8" to 2" / 82°
CTS 50 from 5/8" to 2 1/8" / 90°



Detachable Chip Guard

Protects against flying chips when drilling



ZSS 050 – MAB 485 and MAB 525
ZSS 500 – MAB 825 and MAB 845

Quick-Change Tapping Chucks

Part No. **GSW.830C** tapping chuck includes two variable clamp collets to tap 3/8" to 1 1/8". It is the least expensive system if you will tap more than 4 sizes. **GSW.830C** has an MT3 connection.

For use with all MT3 drills.



Variable clamp collets for use in tap chuck No. **GSW.830C**:
 Part No. **GST-160** for shanks 3/8" – 5/8".
 Part No. **GST-230** for shanks 5/8" – 7/8".



**GSW 444
 Quick-
 Change
 Chuck**

Part No. **GSW 444** quick-change tapping chuck with MT4 connection (for MAB 1300). Collets not included.

Order Number	Tap Collet	Shank Diameter	Square Drive
GSS.420	20mm	16mm	12mm
GSS.422	22mm	18mm	14.5mm
GSS.427	27mm	20mm	16mm
GSS.433	33mm	32mm	20mm
GSS.442	42mm	32mm	24mm



**GSS-4xx
 Collet**

Clamping Devices

MobilCLAMP

A true advance in magnetic drilling technology: MobilCLAMP converts a magnetic drilling machine into a portable drill press.

MobilCLAMP extends the functionality of your portable magnetic drill - converting it to a drill press that can be easily transported to the jobsite. This unit makes it possible to drill, countersink, ream or tap small parts in any location with a flat surface.

The magnetic drill can be mounted onto the MobilCLAMP with only the power of the machine's magnet - no screws, clamps or other connections between the drill and the base. The magnetic drill becomes a multi-purpose machine for applications involving an annular cutter, twist drill, tap, countersink or reamer.

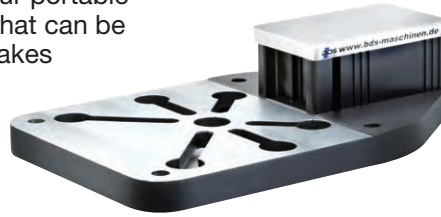

Drill not included.

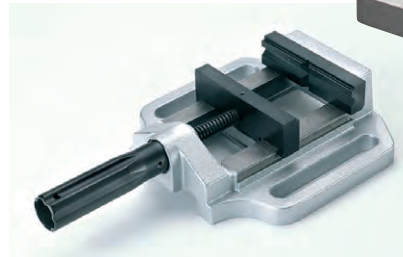

MobilCLAMP	
Order No.	ZMC 200 N
Jaw Width	4" (100mm)
Clamping Range	4" (100mm)

ZMC 200 N includes ZMC 200 base, ZST 300 vise, (2 qty.) ZTN 100 screw and (2 qty.) ZSN 100 hexagon nut with collar

Drilling stand and vise for hand drills



Drill not included.

- Industrial drilling pillars for commercial hand drills with 43mm chuck journal diameter.
- Optimum stability by cast base plate combined with a pillar top of the MAB series.
- Versatile usability by a drill vise with 4" (100mm) jaw width (special accessories).
- Screws for slots are available for additional security under higher loads (special accessories).
- Working stroke of 9" - 17" (230 - 425mm).

Magnetic Drilling Pillar

Order No. **MBS 300**

For hand drills with a 1-11/16" collar diameter and 7" stroke.



Drill not included.

Vise



Order No. **ZST 300**
 jaw width: 4" (100mm)
 clamping range: 4" (100mm)

Drilling Pillar

Order No. **ZBS 100**



Accessories

- Screws for T-Slots – Order No. **ZTN 100**
- Hexagon Nut with Collar – Order No. **ZSM 100**

Vacuum Plates

For applications where drill alone will not adhere to surface

Vacuum Plate for Channeled Plates

Order No. **ZAV 301** (vacuum plate only)
Order No. **ZAV 310** (vacuum plate and vacuum pump, 110V)

Ideal for channeled plates. High-performance vacuum pump with circular oil lubrication. Clamping plate diameter: 11.8"

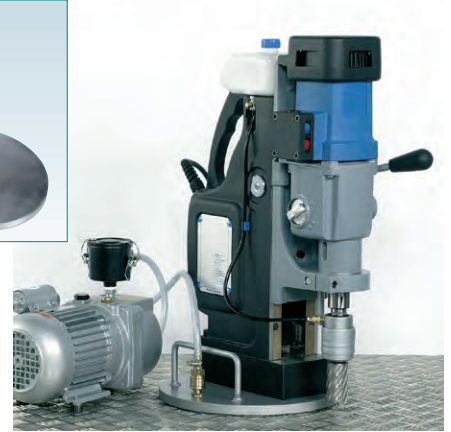

Vacuum Plate for Smooth Surfaces

Order No. **ZAV 401** (vacuum plate only)
Order No. **ZAV 410** (vacuum plate and vacuum pump, 110V)

Ideal for smooth surfaces. High-performance vacuum pump with circular oil lubrication. Clamping plates with two suction surfaces and cut-through drilling area.

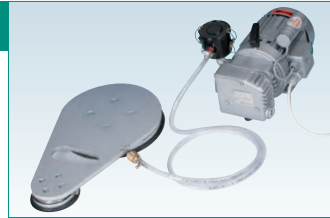

Metal Chip Cleanup Tools

- Easily clean up sharp-edged drill chips, screws and other metal parts
- Ideal for hard-to-reach spaces

Power Cleaner – POW 200

Two-in-one tool for removing chips



- Hook pulls away metal swarf from drill
- Brush cleans fine chips



Power Worker – POW 100

Simple cleanup of metal chips

- Items are safely ejected off of Power Worker without hand contact
- Rare earth magnet cleans metal parts and shavings



Pipe Saddle Clamp System

Ensures safe, secure drilling of pipes and tubular material



Ideal for applications requiring the flexibility of clamping on pipes from 3-1/4" to 20" diameter. These pipe clamp systems are flexible and easy to use. Swivelling V-blocks fit the contour of the pipe while the heavy-duty tension chains securely affix the clamps to the piece being drilled. The drilling position can be easily and safely adjusted.



ZRO 250 Pipe Saddle Clamp System

Pipe diameters 3¹/₄" - 10"

Chain length: 35¹/₂"

If using on pipe larger than 10", need 1 qty. ZRO 001 extension chains.

For models: MABasic 200, MABasic 400, MABasic 450, MAB 455, MAB 465, MAB 485 and CSU 32RL



ZRO 500 Pipe Saddle Clamp System

Pipe diameters 6" - 20" (extension chain available)

Chain length: 65"

If using on pipe larger than 20", need 2 qty. ZRO 001 extension chains.

For models: MABasic 850, MAB 525, MAB 825, MAB 845, CSU 50 Series, CSU 100/3RL, AB-4300-2 and HB 4400

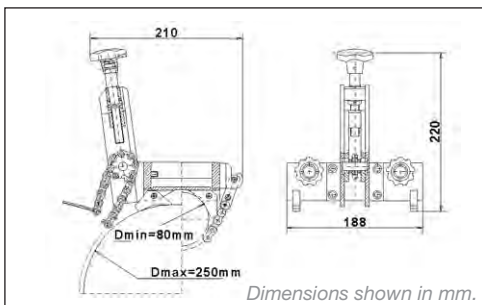

Order No. **ZRO 001** extension chain for ZRO 250 and ZRO 500 pipe saddle clamps. 35" length.

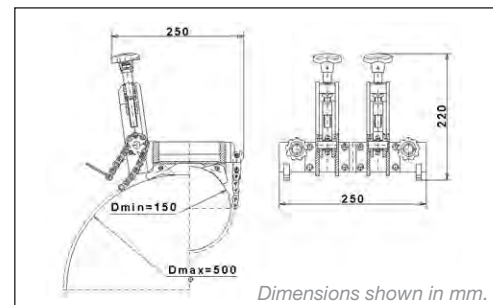

Electric Drills and Drive Units

High-torque, multi-gearred and variable-speed motors



Model EHB 16/2.4 S R/L C



Model EHB 20/2.4



Model EHB 32/4.2



Model EHB 16/1.4 S



Model EAU 34/4 CB



Model EAU 36/4 R R/L CB

Heavy-Duty Drills for Industry and Construction:

- High-torque output
- Variable-speed, two- and four-gearred drills for optimum speed selection
- Reversible motors and electronic torque control on selected models
- Ideal for special applications including valve turning, tube rolling and other jobs
- Safety slip clutch on 1¹/₄" capacities to protect operator and tool
- Drilling capacities up to 1¹/₄" in steel
- Special OEM motors available on request
- One-year warranty



Model No.	Motor Power (Amps)	Voltage	Load Speed (RPM)	Drilling Capacity in Steel	Max. Torque Output (ft./lbs.)	Reversible	Chuck/Arbor	Weight (lbs.)
EHB 16/1.4 S	7.3	110V	0-500	5/8"	12	NO	5/8" Keyless	6.8
EHB 16/1.4 S R/L	9.6	110V	0-450	5/8"	19	YES	5/8" Keyless	7
EHB 16/2.4 S R/L C	10	110V	0-430/0-760	5/8"	19	YES	5/8" Geared	7
EAW 16/2 R/L	9	110V	510/950	N/A	8	YES	5/8" X 16 UN	7
EHB 20/2.4	10.5	110V	250/450	3/4"	32	NO	MT2	9.2
EHB 32/4.2	15.5	110V	110/175/245/385	1 ¹ / ₄ "	112	NO	MT3	15.2
EAU 34/4 CB**	20	110V	80/130/360/570	-	203	YES	MT3	19.5
EAU 36/4 R R/L CB** with 4-speed gearbox and variable speed	22	110V	50-120 80-190 110-270 180-420	-	187	YES	MT3	20

* All units available in 220 Volt / 50Hz

** EAU 34/4 CB and EAU 36/4 R R/L CB include control box Special Motors available upon request.

Electric Drills and Drive Units

Slow Speed: two-gear, variable-speed reversible motors



Model ETE 32/2.3 R/RL
(shown with optional Square Drive adapter)

- High-torque, two-gear and variable-speed reversible motors
- Ideal for drilling, reaming and tapping steel
- Driving applications include mills, spindles, bar boring, pipe beveling and valve turning
- Perfect for tube rolling and expanding for fire tube and water tube boilers
- Mechanical safety clutch prevents operator injury or damage to the tool
- Morse Taper #3 arbor
- One-year warranty



Model EHB 32/2.2 R/RL
Model ETE 32/2.3 R/RL



Up to 1¹/₄" twist drill capacity

1¹/₂" and 3³/₄" Square Drive accessories allow motor compatibility for various drive applications.*



Model No.	Motor Power (Amps)	Voltage**	Load Speed (RPM)	Drilling Capacity in Steel	Tube Rolling (max.)	Reversible	Torque Output (ft./lbs.)	Torque Control	Arbor	Weight (lbs.)
EHB 32/2.2 R/RL	16.3	110V	60-140/ 200-470	1 ¹ / ₄ "	2"	YES	95 max.	YES	MT3	14
ETE 32/2.3 R/RL	16.3	110V	30-75/ 90-230	N/A	3" ***	YES	174 max.	7	MT3	15

** All units available in 220 Volt / 50Hz

*** With Expander (Up to 2¹/₂" with Bead Roller)

* 1¹/₂" Square Drive with MT3 – Part No. 830-1230-050

3³/₄" Square Drive with MT3 – Part No. 830-1230-075

Special Electric Motor Options

High-torque, reversible electric drill motors for custom applications

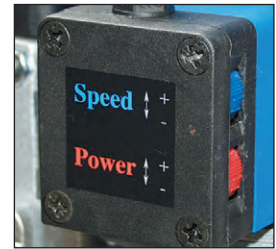
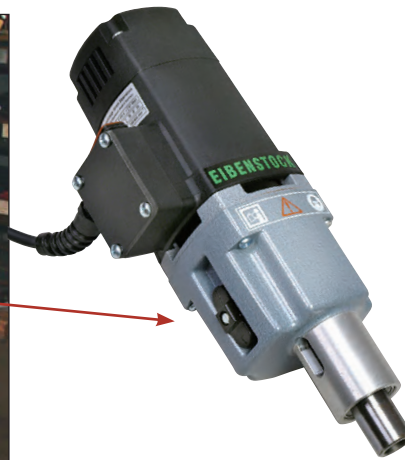
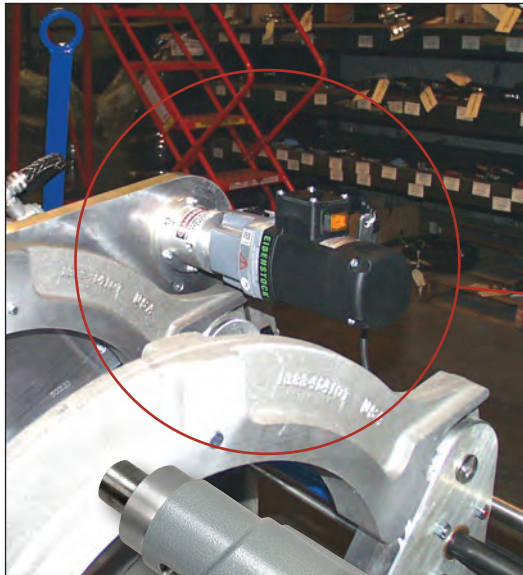

Control Boxes with On/Off, Variable Speed

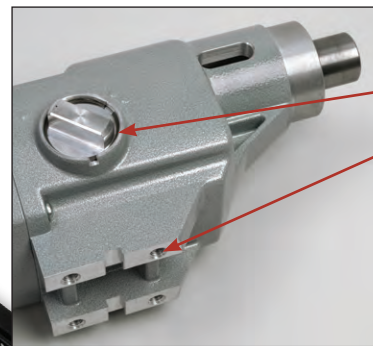

**Gear Selection Knob
Holes for Mounting
(Model EAU 34/4 only)**

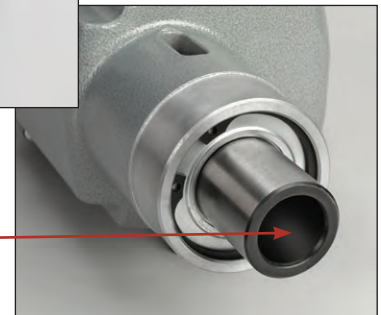

**Spindle Options:
MT2 / MT3
Square Drive
or Threaded**

Driving applications include mills, spindles, bar boring, tube rolling, valve turning and more.

Custom Design Options Include:

- ✓ **Forward/Reverse**
- ✓ **Variable Speeds**
- ✓ **Multiple Gears**
- ✓ **Spindle: MT or Special**
- ✓ **Multifunctional Control Boxes or Handles**
- ✓ **1/2 to 4 HP**
- ✓ **Modular Design**

Contact us today to configure the motor that meets your specific driving applications.

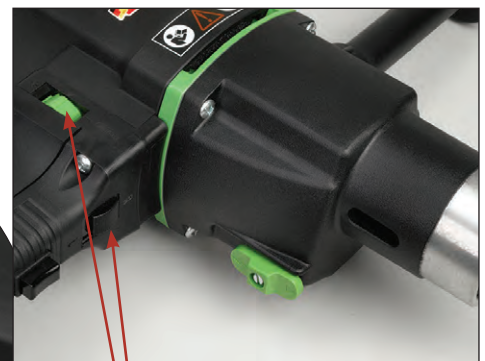

**Forward/Reverse Control
Electronic Torque Control
Variable-speed Dial**

Custom-Engineered Machines

Design a custom machine for your specific needs

Unusual applications require unique solutions. We can help you build custom drills for a wide variety of applications. With our considerable experience building custom drills, our engineers can assist you to create machines that can drill on uneven surfaces, in various directions, and more.

We enjoy a challenge! Contact us today for a professional solution for your unique application. Our capabilities include:

- In-house CAD design
- Prototype construction
- Manufacturing of special accessories

Custom Machine Options Include:

- ✓ **Reverse Drilling**
- ✓ **Alternative Mounting Configurations**
- ✓ **Magnet Variations**
- ✓ **Motor Customization**
- ✓ **Adjustable Drilling Depth**

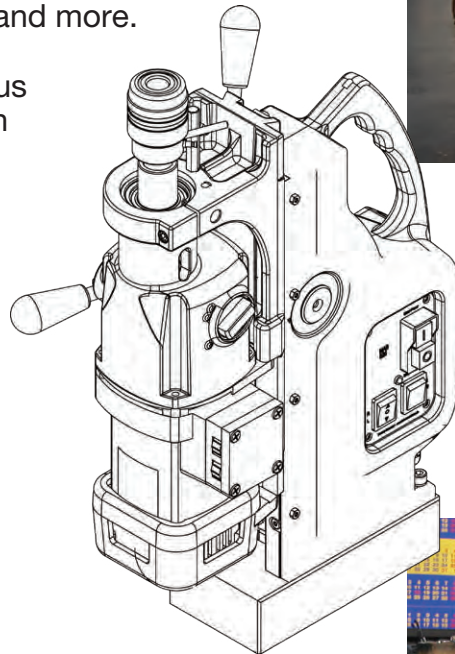

Machine rendering above shows reverse-mount motor for drilling upside down.

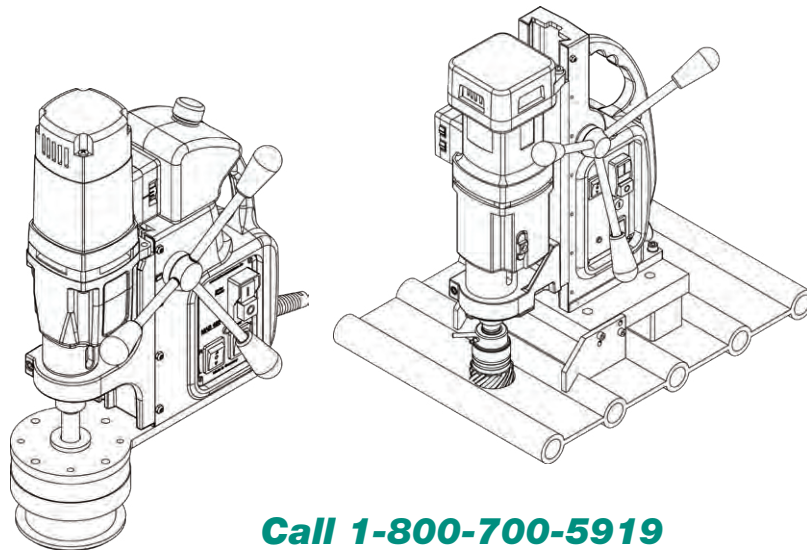

**Call 1-800-700-5919
for design assistance.**

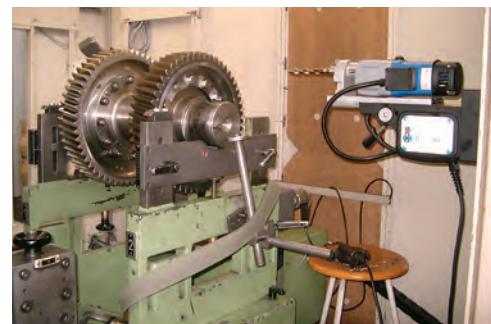
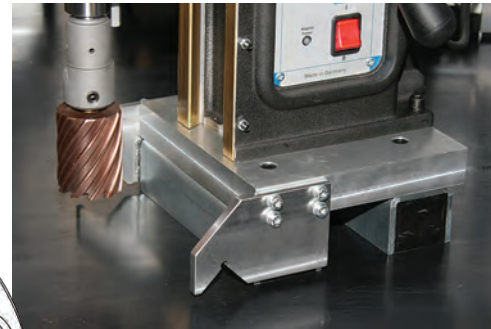

Pneumatic Drills and Drive Units

High-torque reversible drilling and tapping machines

ATEX



- High-torque reversible drilling, tapping and threading machines
- Ideal for drilling, reaming, tube rolling, tube expanding and tapping
- Special applications include mills, spindles, slides, controllers, pipe tapping, valve turning and more
- Drill chucks and Morse Taper arbors
- Hammer drills for drilling concrete with up to 2200 blows per minute
- Special OEM air motors available on request
- 6-month warranty

Morse Taper Drills w/ Feed Spindle



Model
2 2089 0030
with reverse and
safety twist throttle

D-handle Drills



Model
2 1310 0010

Pneumatic Hammer Drills



Model 2 1266 0010

Pneumatic Pistol Drills



Model
2 1261 0010



See page 78
for Rotary
Hammer Drills

Model No.	Motor Power (HP)	Load Speed (RPM)	Reversible	Chuck/ Arbor	Drilling Capacity in Steel	Tube Rolling Capacity	Torque Output (ft./lbs.)	CFM at 90 PSI	Length	Feed Length	Weight (lbs.)
Pistol Drills											
2 1261 0010	0.7	850	NO	1/2" Chuck	1/2"	N/A	7 max.	21	9 ³ / ₄ "	N/A	4.6
Hammer Drills (for concrete and underwater applications)											
2 1266 0010	0.75	950	NO	1/2" Chuck	1/2"	N/A	7 max.	21	12"	N/A	6.7
D-Handle Drills											
2 1310 0010	0.8	650	NO	1/2" Chuck	1/2"	N/A	8 max.	24	12 ¹ / ₂ "	N/A	12
2 1311 0010	0.8	650	NO	MT1	5/8"	N/A	8 max.	24	11"	N/A	12
Morse Taper Drills w/ Feed Spindle											
2 2089*	1.7	250	YES	MT3	1 ¹ / ₄ "	1"	36 max.	24	26 ¹ / ₂ "	1 ⁵ / ₈ "	28
2 2506*	2.5	220	YES	MT3	1 ¹ / ₄ "	2"	63 max.	70	26 ¹ / ₂ "	2 ¹ / ₂ "	32
2 2502*	2.5	80	YES	MT4	2"	2 ¹ / ₂ "	173 max.	70	26 ¹ / ₂ "	2 ¹ / ₂ "	37

* The last four digits of the Model No. identify the type of throttle.
Please specify the four digits when ordering: 0010 for Lever Throttle or 0030 for Safety Twist Throttle.

Corner Drills and Drives



Pneumatic, electric and hydraulic: high-torque drilling, reaming and driving units



Model 2 1801 0030

Corner Drills and Bridge Reamers

- Small side-to-side distance for tight spaces
- Self-closing roll throttle
- Built-in oiler for motor
- Ideal for bridge reaming and drilling applications
- 6-month warranty
- Visit www.csunitec.com for dimensions

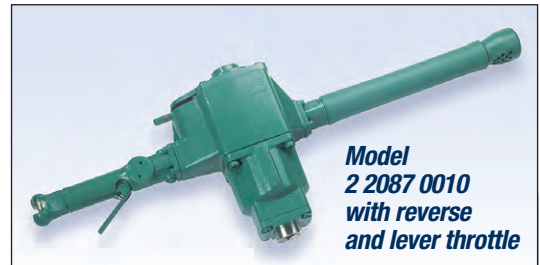
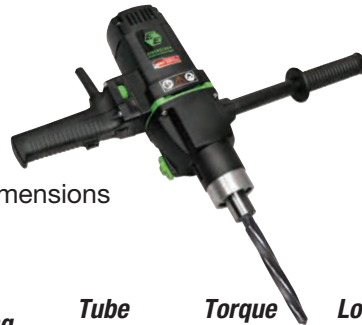

Model 2 2087 0010 with reverse and lever throttle

- Ideal for heavy-duty reaming, tube expanding and tapping
- Perfect for special driving applications, including pipe tapping and valve turning

Square Drive Accessories

- 2 2089 7020 – 7/8" Male Sq. Drive to 3/4" Male Sq. Drive
- 2 2089 7070 – 7/8" Male Sq. Drive to 1" Male Sq. Drive
- 6 1016 7940 – 7/8" Male Sq. Drive to 1" Male Sq. Drive with retaining pin

Pneumatic Corner Drill Model No.	Morse Taper	Drilling (in steel)	Reaming (in steel)	Tube Rolling Capacity	Torque Output (ft./lbs.)	Load Speed (RPM)	Motor Power (HP)	CFM at 90 PSI	Length	Weight (lbs.)
Nonreversible										
2 1602 0030	#1	5/8"	1/2"	N/A	7	500	0.7	21	12.5"	7
2 1701 0030	#2	7/8"	5/8"	N/A	35	270	1.8	49	20.9"	19
2 1801 0030	#3	1 1/4"	1"	N/A	53	260	2.6	63	22.5"	25
Reversible										
2 2104 0030	#4	2 1/8"	2"	2"	86	2 1/2"	3.0	71	23.8"	37

Model No. 2 1602 0030 has a 3/8" NPT air inlet. 1/2" (13mm) hose is recommended. All other models have 3/4" NPT air inlet. A 1/2" (13mm) hose is recommended for model 2 1701 0030. A 5/8" (15mm) hose is recommended for models 2 1801 0030 and 2 2104 0030.

Hydraulic Corner Drill Model No.	Morse Taper	Drilling (in steel)	Reaming (in steel)	Tube Rolling Capacity	Torque Output (ft./lbs.)	Load Speed (RPM)	Motor Power (HP)	Oil Flow/PSI	Length	Weight (lbs.)
2 1806 0010	#3	1 1/4"	1"	N/A	60	220	3.8	4 GPM @ 2000	21"	25

Electric Drill Model No.	Motor Power (Amps)	Voltage	Load Speed (RPM)	Drilling (in steel)	Tube Rolling Capacity	Reversible	Torque Output (ft./lbs.)	Torque Control	Arbor	Weight (lbs.)
EHB 32/2.2 R/RL	16.3	110	60-140, 200-470	1 1/4"	2"	Yes	92 max.	Yes	MT3	14

Pneumatic Drive Unit Model No.	Square Drive ID	Torque Output (ft./lbs.)	Load Speed (RPM)	Reversible	Tube Rolling Capacity	Tapping Capacity	Motor Power (HP)	CFM at 90 PSI	Height x Length	Weight (lbs.)
2 2081*	13/16"	413	20	YES	3"	1 1/2"	1.35	53	10.9" x 26.5"	29
2 2087*†	7/8"	413	5/8"	N/A	3"	1 1/2"	1.35	53	10.9" x 26.5"	29
2 2087*†	7/8"	138	2"	2"	2"	3/4"	1.35	53	10.9" x 26.5"	29

* The last four digits of the Model No. identify the type of throttle. † Square drive accessories available (see above). Please specify the four digits when ordering: 0010 for Lever Throttle or 0030 for Safety Twist Throttle.

SDS Rotary Hammer Drills

ATEX

Pneumatic and hydraulic: powerful percussion drilling for concrete and masonry

- SDS Plus or SDS Max models
- Safety clutch protects against overloading and jamming
- Hammer drill holes in concrete, brick and masonry
- Rotary drilling mode for straight drilling of steel and wood
- Open center hydraulic standard, closed center optional

SDS Max – Modes of Operation

2" bit capacity for drilling concrete and masonry

Hammer with Rotation
Ideal for concrete drilling

Rotation Only For drilling steel and wood (not reversible)



Air Model 2 2417 0010
SDS Max



Hydraulic Model 2 2418 0010
SDS Max

Second handle position
SAE #8 port for hydraulic hose connection



Air Model 2 2404 0010
SDS Plus up to 1" dia.



SDS Plus – Hammer and Drill

1" bit capacity for drilling concrete and masonry

Drill concrete anchor holes, thru holes, piping and mechanical openings for construction and repair work. Switches to rotary drilling mode for steel and wood.



Hydraulic Model 2 2426 0010
SDS Plus

SAE #8 oil port

Closed Center Flow Control Valve

Optional accessory – Part No. 38632



SDS Drill Bits



Small Masonry Bits
SDS Plus up to 1" dia.



Large Masonry Bits
SDS Max up to 2" dia.

Hydraulic Pressure Reducing Valves

PRV Part No. 2 2406 9700 reduces output pressure of standard hydraulic power units from 2000 PSI (140 bar) to 1160 PSI (80 bar). Included with SDS Plus Hydraulic Hammer Drill 2 2426 0010 and SDS Max Hydraulic Hammer Drill 2 2418 0020.

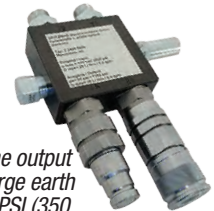

Pressure Reducing Valve Part No. 2 2406 9900 reduces the output pressure of larger-output hydraulic units (i.e. backhoes, large earth tractors, excavators, service trucks, etc.) from max. 5075 PSI (350 bar) to 1160 PSI (80 bar) working pressure.

Pneumatic Hammer Drill Model No.	Blows/Minute (BPM)	Drill Speed (RPM)	Solid Bit Capacity (concrete)	Core Bit Capacity (concrete)	Twist Drill (wood)	Motor Power (HP)	CFM at 90 PSI	Tool System	Dimensions (inches)	Weight (lbs.)
2 1266 0010*	0-2000	0-950	1/2" dia.	1" dia.	3/8" dia.	0.75	21	1/2" Chuck	12 x 8 1/2 x 4	7
2 2404 0010	0-3000	0-625	1" dia.	3" dia.	3/4" dia.	0.70	21	SDS Plus	16 x 8 1/2 x 4	11
2 2404 0030*	0-3000	0-625	1" dia.	3" dia.	3/4" dia.	0.70	21	SDS Plus	16 x 8 1/2 x 4	11
2 2417 0010*	0-2500	0-250	2" dia.	6" dia.	1 1/4" dia.	1.60	53	SDS Max	19 1/2 x 9.8 x 4 1/2	26

* Underwater model – optional underwater air tool line conditioner to displace moisture, Part No. MS 9105. See page 79.

Hydraulic Hammer Drill Model No.	Blows/Minute (BPM)	Drill Speed (RPM)	Solid Bit Capacity (concrete)	Core Bit Capacity (concrete)	Twist Drill (wood)	Motor Power (HP)	Oil Flow/PSI	Tool System	Dimensions (inches)	Weight (lbs.)
2 2426 0010	0-3400	0-625	1" dia.	3" dia.	3/4" dia.	0.8	5.8-13.2 GPM @ 1160 PSI	SDS Plus	18 x 10 1/4 x 4	15
2 2418 0010	0-2500	0-250	2" dia.	6" dia.	1 1/4" dia.	1.8	2.6-13.2 GPM @ 1160 PSI	SDS Max	16 x 8 1/2 x 4	11
2 2418 0020	Same as 2 2418 0010 above. Includes 2 2406 9700 Pressure Reducing Valve for 2000 PSI.									

* Hydraulic Hammer Drills operate at hydraulic pressures of 1160 PSI max. Pressure reducing valves are available to reduce pressure from 2000 PSI or 5000 PSI. See above. Available with optional closed center.

SDS ROTARY HAMMER DRILLS

Woodboring Air Drills, Reversible

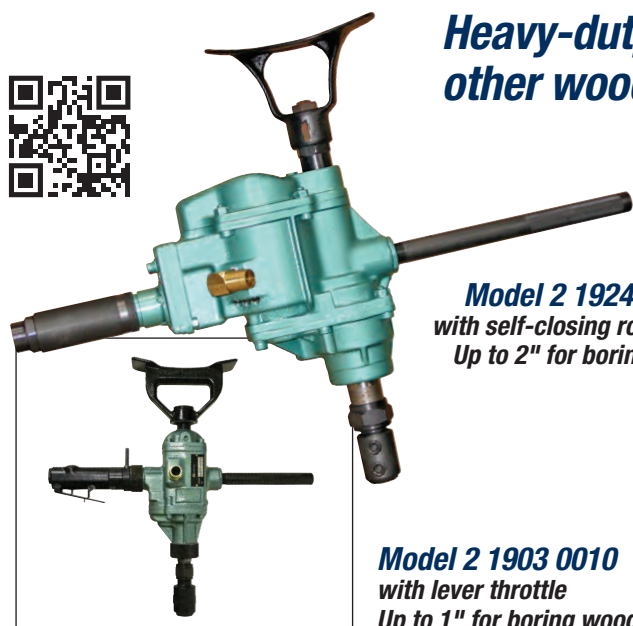

Heavy-duty power for underwater drilling and other wood boring applications



Model 2 1924 0010
with self-closing roll throttle
Up to 2" for boring wood

Model 2 1903 0010
with lever throttle
Up to 1" for boring wood

- Ideal for drilling wood in marine timbers, underwater use and railroad repair work
- Thrust bearing support for long life and efficient operation
- Lever throttle and durable spur gearing
- Breast plate and dead handle included
- Includes threaded exhaust port
- Use underwater with Air Tool Line Conditioner (shown below)

Accessories and woodboring drill bits from 1/2" dia. to 1 1/8" dia. in lengths from 12" to 36"

Specifications	Model 2 1903 0010	Model 2 1924 0010	Model 2 1924 0010
Capacity in Wood	1" Diameter	2" Diameter	3" Diameter
Reversible	Yes	Yes	Yes
Power	2 HP	3 HP	3 HP
Chuck Style	1/2" Woodboring	1/2" Woodboring	1/2" Woodboring
Spindle	Stub Taper	#2 Morse Taper	#3 Morse Taper
Free Speed	750 RPM	700 RPM	380 RPM
Recommended Hose Size	1/2"	1/2"	1/2"
Overall Height	17 1/2"	18 1/2"	18 1/2"
Weight	14 1/2" lbs.	24 3/4" lbs.	24 3/4" lbs.
Air Inlet Thread	1/2" ID	1/2" ID	1/2" ID
Air Exhaust Thread	1/2" NPT	1/2" NPT	1/2" NPT
Air Consumption at 90 PSI	39 CFM	39 CFM	39 CFM
Optional Geared Drill Chuck	Part No. DE-99C	Part No. IBC 22 (MT2)	Part No. IBC 21 (MT3)

AirPac Extends life of pneumatic power tools



Model CSAP-2

- Eliminates air motor downtime caused by water and dirt
- Connections for two tools; max. air flow 185 CFM

- Removes moisture and dirt from air lines; a float valve automatically ejects water and dirt
- Includes automatic oiler; prevents tools from freezing in cold environments

Air Tool Line Conditioner

Underwater air tool conditioner for marine applications. Displaces moisture and inhibits rust/corrosion of air motors.

MS 9105 – 1 quart/liter



Nut Runners - High Torque



Pneumatic and hydraulic: ideal for turning valves, tightening, tapping, reaming, pipe beveling, expanding and more



- Worm gear drive provides high torque – up to 554 ft.-lbs.
- Lightweight and reversible
- Compact angle head allows access to confined spaces



**Model
6 1055 0075**

Model numbers pictured above (listed from top to bottom): **6 1055 0075** (with male drive), **6 1055 0010** (female), **6 1014 0075** (with male drive)

Available with Male or Female Square Drives, in a variety of sizes



Male Sq. Drive Head
1/2" or 3/4"



Female Sq. Drive Head
3/4" or 7/8"

Square Drive Accessories

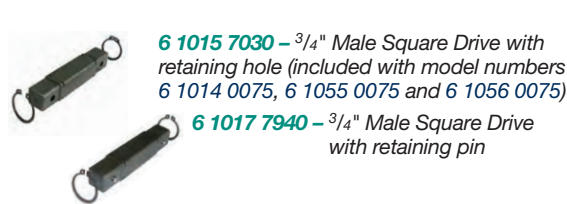

6 1015 7030 – 3/4" Male Square Drive with retaining hole (included with model numbers 6 1014 0075, 6 1055 0075 and 6 1056 0075)

6 1017 7940 – 3/4" Male Square Drive with retaining pin



6 1018 7940 – 1/2" Male Square Drive with retaining pin (included with model numbers 6 1014 0099, 6 1055 0099 and 6 1056 0099)

6 1016 7940 – 1" Male Square Drive

Pneumatic Nut Runner Model No.	Square Drive F=Female M=Male	Stall Torque at 90 PSI (ft.-lbs.)	Free Speed (RPM)	Load Speed (RPM)	Power (HP)	CFM at 90 PSI	Side to Center Distance	Length	Weight (lbs.)	Air Connection	Hose ID
6 1014 0075*	3/4" M	95	200	100	0.9	46	1"	22"	11	3/8" NPT	1/2"
6 1014 0099	1/2" M	95	200	100	0.9	46	1"	22"	11	3/8" NPT	1/2"
6 1055 0075*	3/4" M	405	40	22	0.9	46	1"	21"	10	3/8" NPT	1/2"
6 1055 0099	1/2" M	405	40	22	0.9	46	1"	21"	10	3/8" NPT	1/2"
6 1056 0075*	3/4" M	133	120	67	0.9	46	1"	21"	11	3/8" NPT	1/2"
6 1056 0099	1/2" M	133	120	67	0.9	46	1"	21"	11	3/8" NPT	1/2"
6 1057 0075*	3/4" M	73.5	250	125	0.9	46	1"	21"	11	3/8" NPT	1/2"
6 1057 0099	1/2" M	73.5	250	125	0.9	46	1"	21"	11	3/8" NPT	1/2"
6 1061 0010	7/8" F	405	40	22	0.9	46	1"	21"	11	3/8" NPT	1/2"

* Also available with 3/4" Female Square Drive – use 0010 instead of 0075 in model number.

Hydraulic Nut Runner Model No.	Square Drive F=Female M=Male	Drive Torque (ft.-lbs.)	Free Speed (RPM)	Load Speed (RPM)	Power (HP)	Oil Flow (GPM)	Oil Pressure (PSI)	Side to Center Distance	Length	Weight (lbs.)	Connection Quick Couplers
3 6242 0010*	3/4" F	369	40	22	1.6	4-13	90-2000	1"	20"	22	1/2" FF
3 6243 0010*	3/4" F	125	180	90	1.6	4-13	1300-2000	1"	20"	22	1/2" FF

* Also available with 1/2" (3 6242 0099) and 3/4" (3 6242 0075) Male Square Drive

PNEUMATIC AND HYDRAULIC NUT RUNNERS